

**INSTRUCTION MANUAL
ROTATING LASER**

RL-HV series

HOW TO READ THIS MANUAL

Thank you for selecting the RL-HV series.

- Please read this instruction manual carefully, before using this product.
- The specifications and general appearance of the instrument are subject to change without prior notice and without obligation by TOPCON CORPORATION and may differ from those appearing in this manual.
- The content of this manual is subject to change without notice.
- Some of the diagrams shown in this manual may be simplified for easier understanding.
- Always keep this manual in a convenient location and read it when necessary.
- This manual is protected by copyright and all rights are reserved by TOPCON CORPORATION.
- Except as permitted by Copyright law, this manual may not be copied, and no part of this manual may be reproduced in any form or by any means.
- This manual may not be modified, adapted or otherwise used for the production of derivative works.

Symbols

The following conventions are used in this manual.



: Indicates precautions and important items which should be read before operations.



: Indicates the chapter title to refer to for additional information.



: Indicates supplementary explanation.

[Menu mode] etc. : Indicates operation keys and selection items on the screen.

Notes regarding manual style

- Except where stated, "RL-HV" means RL-HV series (RL-HV 1S / RL-HV 2S) in this manual.
- Except where stated, screens and illustrations appearing in this manual are of RL-HV 2S.
- "Laser Manager" is the name of software used to remotely control and support laser products. It works on devices such as iPhone and Android™.
- App Store is a trademark or a service mark of Apple Inc., registered in the U.S. and other countries.
- iPhone is a trademark of Apple Inc., registered in the U.S. and other countries.
- Android and Google Play are trademarks of Google LLC.
- QR Code is a registered trademark of DENSO WAVE.
- *Bluetooth*® is a registered trademark of Bluetooth SIG, Inc.
- All other company and product names featured in this manual are trademarks or registered trademarks of each respective organization.



CONTAINS NI-MH BATTERY.
MUST BE RECYCLED OR DISPOSED OF PROPERLY.

NI-MH

CONTENTS



1. PRECAUTIONS FOR SAFE OPERATION	1
2. PRECAUTIONS	4
3. LASER SAFETY INFORMATION	8
4. PRODUCT OUTLINE	9
4.1 RL-HV	9
4.2 Level Sensor LS-80X	12
5. USING THE BATTERY	15
5.1 Battery Charging	15
5.2 Installing/Removing the Battery	16
5.3 Using the Dry Batteries	17
■ RL-HV	17
■ LS-80X	18
6. BASIC OPERATION	19
6.1 Setting up the instrument	19
■ Horizontal Rotation	19
■ Example Operational	20
6.2 Height Alert Function	22
6.3 <i>Bluetooth</i> Connection	23
■ Installing Laser Manager	23
7. APPLIED OPERATIONON	24
7.1 Setting Grades	24
■ How to set grades (In case of 1S)	25
■ How to set grades (In case of 2S)	26
■ Example of how to set up	27
■ Matching Mode (Manual Slope)	29
7.2 Line Control (manual vertical beam alignment)	32
8. CHANGING THE SETTINGS	34
8.1 Masking (Laser beam shutter) setting	34
8.2 Speed setting	35
8.3 Manual Mode ON/OFF setting	36
8.4 Height Alert ON/OFF	37
9. ERROR DISPLAYS	38
10. CHECK AND ADJUSTMENTS	39
10.1 Check and Adjust Horizontal Rotation	39
■ Horizontal Rotation Grade Error	39
■ Horizontal Rotation Cone Error	42
■ Grade Setting Error	43
10.2 Vertical Calibration	44
■ Checking Calibration	44
■ Vertical calibration and adjustment	44
11. SPECIFICATIONS	46
12. REGULATIONS	48



1. PRECAUTIONS FOR SAFE OPERATION

For the safe use of the product and prevention of injury to operators and other persons as well as prevention of property damage, items which should be observed are indicated by an exclamation point within a triangle used with WARNING and CAUTION statements in this instruction manual.

The definitions of the indications are listed below. Be sure you understand them before reading the manual's main text.



Definition of Indication

	WARNING	Ignoring this indication and making an operation error could possibly result in death or serious injury to the operator.
	CAUTION	Ignoring this indication and making an operation error could possibly result in personal injury or property damage.



-  This symbol indicates items for which caution (hazard warnings inclusive) is urged. Specific details are printed in or near the symbol.
-  This symbol indicates items which are prohibited. Specific details are printed in or near the symbol.
-  This symbol indicates items which must always be performed. Specific details are printed in or near the symbol.

General

Warning



-  Do not use the unit in areas exposed to high amounts of dust or ash, in areas where there is inadequate ventilation, or near combustible materials. An explosion could occur.
-  Do not perform disassembly or rebuilding. Fire, electric shock, burns or hazardous radiation exposure could result.
-  When securing the instrument in the carrying case make sure that all catches, including the side catches, are closed. Failure to do so could result in the instrument falling out while being carried, causing injury.













Caution

-  Do not use the carrying case as a footstool. The case is slippery and unstable so a person could slip and fall off it.
-  Do not place the instrument in a damaged case or in a case with a damaged belt. The case or instrument could be dropped and cause injury.
-  Do not wield or throw the plumb bob. A person could be injured if struck.







Power Supply

Warning



-  Do not disassemble or rebuild the battery or the charger, nor expose to heavy shocks or vibration. Sparking, fire, electric shock or burns could result.
-  Do not short circuit. Heat or ignition could result.
-  Do not place articles such as clothing on the battery charger while charging batteries. Sparks could be induced, leading to fire.

-  Do not use voltage other than the specified power supply voltage. Fire or electrical shock could result.
 -  Do not use batteries other than those designated. An explosion could occur, or abnormal heat generated, leading to fire.
 -  Do not use damaged power cords, plugs or loose outlets. Fire or electric shock could result.
 -  Do not use power cords other than those designated. Fire could result.
 -  Use only the specified battery charger to recharge batteries. Other chargers may be of different voltage rating or polarity, causing sparking which could lead to fire or burns.
 -  Do not use the battery or charger for any other equipment or purpose. Fire or burns caused by ignition could result.
 -  Do not heat or throw batteries or chargers into fire. An explosion could occur, resulting in injury.
 -  To prevent shorting of the battery in storage, apply insulating tape or equivalent to the terminals. Otherwise shorting could occur, resulting in fire or burns.
 -  Do not use the battery or the battery charger if its terminals are wet. Resultant poor contact or shorting could lead to fire or burns.
 -  Do not connect or disconnect power supply plugs with wet hands. Electric shock could result.
-  **Caution**
-  Do not touch liquid leaking from batteries. Harmful chemicals could cause burns or blisters.

Tripod

-  **Caution**
-  When mounting the instrument to the tripod, tighten the centering screw securely. Failure to tighten the screw properly could result in the instrument falling off the tripod, causing injury.
 -  Tighten securely the leg fixing screws of the tripod on which the instrument is mounted. Failure to tighten the screws could result in the tripod collapsing, causing injury.
 -  Do not carry the tripod with the tripod shoes pointed at other persons. A person could be injured if struck by the tripod shoes.
 -  Keep hands and feet away from the tripod shoes when fixing the tripod in the ground. A hand or foot stab wound could result.
 -  Tighten the leg fixing screws securely before carrying the tripod. Failure to tighten the screws could lead to the tripod legs extending, causing injury.

Bluetooth wireless technology

-  **Warning**
-  Do not use within the vicinity of hospitals. Malfunction of medical equipment could result.
 -  Use the instrument at a distance of at least 22 cm from anyone with a cardiac pacemaker. Otherwise, the pacemaker may be adversely affected by the electromagnetic waves produced and cease to operate as normal.

- ⊘ Do not use onboard aircraft. The aircraft instrumentation may malfunction as a result.
- ⊘ Do not use within the vicinity of automatic doors, fire alarms and other devices with automatic controls as the electromagnetic waves produced may adversely affect operation resulting in an accident.

2. PRECAUTIONS

Charging Battery

- Be sure to charge the battery within the charging temperature range.
Charging temperature range: 10 to 40°C
- Use only the specified battery and the battery charger. Failures caused by using other batteries and battery chargers are out of warranty including the main unit.

Warranty policy for Battery

- Battery is an expendable item. The decline in retained capacity depending on the repeated charging/discharging cycle is out of warranty.

Vibration and Impact Protection

- When transporting the instrument, provide protection to minimize risk of severe vibration or impact. Severe vibration or impacts may affect beam accuracy.

Sudden changes of temperature

- A sudden change in temperature may cause water condensation on the glass used for the laser emission part. In such a case, let the instrument stand for a while to allow it to adjust to the temperature prior to actual use.

Storage precautions

- When storing the instrument, keep it in a place not exposed to direct sunlight and at the temperature range from -30 to 60°C.
- Do not store the wet instrument in the carrying case. If any part of the instrument is wet, thoroughly wipe off with soft cloth and leave it dry before storing in the carrying case.

Precautions concerning water and dust resistance



The instrument conforms to IP66 specifications for waterproofing and dust resistance.

- Close the battery holder securely.
- Make sure that moisture or dust particles do not come in contact with the terminal or connectors. Operating the instrument with moisture or dust on the terminal or connectors may cause damage to the instrument.
- Make sure that the inside of the carrying case and the instrument are dry before closing the case. If moisture is trapped inside the case, it may cause the instrument to rust.
- If there is a crack or deformation in the rubber packing for the battery holder, stop using and replace the packing.
- To retain the waterproof property, it is recommended that you replace the rubber packing once every two years. To replace the packing, contact your local dealer.

Other precautions

- Protect the instrument from heavy shocks or vibration.
- Remove batteries before storing when the instrument will not be used for periods on 1 month or more. Batteries may leak fluid when left inside the instrument causing malfunction.
- In addition to the laser beam emitted from the rotating laser, the level sensor may be sensitive to smartphone screens, LED lamps, fluorescent lamps, constriction lamps, and other modulated lights. In this case, turn off these modulated lights that may be the cause, or block them before performing measurement.
- If an object (glass window, car windshield, etc.) that may reflect a laser beam is close to this instrument, the level sensor may malfunction. When using this instrument, block the laser beam to the direction of a reflective object.

Examples of malfunctions:

- The display shows [] even though the location is not a datum position.
- Errors occur for the datum position.
- The display does not show [] even though the location is a datum position.



- Be sure that the laser emitting window of this instrument, and the beam receiving window of the level sensor are free from dirt (oil, water droplets, etc.). The measurement result may be in error if these windows are dirty.

User

- Wear the required protectors (safety shoes, helmet, etc.) when operating.

Maintenance

- Wipe off moisture completely if the instrument gets wet during survey work.
- Wipe away stain or dirt with soft cloth after dusting.
- Clean storage case using cloth moistened with neutral detergent or water. Do not use ether, benzene, thinner or other solvents.
- To clean the instrument or the carrying case, lightly moisten a soft cloth in a mild detergent solution. Wring out excess water until the cloth is slightly damp, then carefully wipe the surface of the unit. Do not use any alkaline cleaning solutions, alcohol, or any other organic solvents on the instrument or display.
- When removing the instrument from the carrying case, never pull it out by force. The empty carrying case should be closed to protect it from moisture.
- Check the tripod for loose fit and loose screws.
- Check the instrument for proper adjustment periodically to maintain the instrument accuracy.

Bluetooth Wireless Technology

- *Bluetooth* function may not be built in depending on telecommunications regulations of the country or the area where the instrument is purchased. Contact your local dealer for the details.
- Use of this technology must be authorized according to telecommunications regulations of the country where the instrument is being used. Contact your local dealer in advance.

 "12. REGULATIONS"

- TOPCON CORPORATION is not liable for the content of any transmission nor any content related thereto. When communicating important data, run tests beforehand to ascertain that communication is operating normally.
- Do not divulge the content of any transmission to any third party.

Radio interference when using *Bluetooth* technology

Bluetooth communication with the RL-HV uses the 2.4 GHz frequency band. This is the same band used by the devices described below. As a result, using the RL-HV within proximity to the above devices may result in interference causing communication failure or reduction of transmission speed.

- Industrial, scientific, and medical (ISM) equipment such as microwaves and pacemakers.
- portable premises radio equipment (license required) used in factory production lines etc.
- portable specified low-power radio equipment (license-exempt)
- IEEE802.11b/IEEE802.11g/IEEE802.11n/IEEE802.11ax standard wireless LAN devices

Although a radio station license is not required for this instrument, bear in mind the following points when using *Bluetooth* technology for communication.

- Regarding portable premises radio equipment and portable specified low-power radio equipment:
 - Before starting transmission, check that operation will not take place within the vicinity of portable premises radio equipment or specified low-power radio equipment.
 - In the case that the instrument causes radio interference with portable premises radio equipment, terminate the connection immediately and take measures to prevent further interference (e.g. connect using an interface cable).
 - In the case that the instrument causes radio interference with portable specified low-power radio equipment, contact your local dealer.
- When using *Bluetooth* function in proximity to IEEE802.11b/IEEE802.11g/IEEE802.11n/IEEE802.11ax standard wireless LAN devices, turn off all devices not being used.
 - Interference may result, causing transmission speed to slow or even disrupting the connection completely. Turn off all devices not being used and vice versa.
- Do not use the RL-HV in proximity to microwaves.
 - Microwave ovens can cause significant interference resulting in communication failure. Perform communication at a distance of 3m or more from microwave ovens.
- Refrain from using the RL-HV in proximity to televisions and radios.
 - Televisions and radios use a different frequency band to *Bluetooth* communications. However, even if the RL-HV is used within proximity to the above equipment with no adverse effects with regard to *Bluetooth* communication, moving a *Bluetooth* compatible device (including the RL-HV) closer to said equipment may result in electronic noise in sound or images, adversely affecting the performance of televisions and radios.

Precautions regarding transmission

- For best results
 - The usable range becomes shorter when obstacles block the line of sight, or devices such as PDAs or computers are used. Wood, glass and plastic will not impede communication but the usable range becomes shorter. Moreover, wood, glass and plastic containing metal frames, plates, foil and other heat shielding elements as well as coatings containing metallic powders may adversely affect wireless communication and concrete, reinforced concrete, and metal will render it impossible.
 - Use a vinyl or plastic cover to protect the instrument from rain and moisture. Metallic materials should not be used.
 - The direction of the *Bluetooth* antenna can have adverse effects upon usable range.
- Reduced range due to atmospheric conditions
 - The radio waves used by the RL-HV may be absorbed or scattered by rain, fog, and moisture from the human body with the limit of usable range becoming lower as a result. Similarly, usable range may also shorten when performing communication in wooded areas. Moreover, as wireless devices lose signal strength when close to the ground, perform communication at as high a position as possible.



- TOPCON CORPORATION cannot guarantee full compatibility with all *Bluetooth* products on the market.

Export Restrictions

These commodities, technology or software were exported in accordance with applicable export control laws and regulations. Diversion contrary to those laws and regulations, as well as the export laws and regulations of any countries of reexport, is prohibited.

In consideration for its purchase of commodities, technology or software from Topcon, Purchaser agrees that it will determine any license requirements to export the items and, as applicable, to reexport or transfer the items, obtain any license or other official authorization, and carry out any customs formalities for the export or reexport of the items. Purchaser agrees that it will not reexport or transfer the commodities, technology or software to Cuba, Iran, North Korea, Syria or Crimea Region of Ukraine without a license or other authorization from all applicable export control authorities. It is also unlawful to receive, use, transfer, or reexport these items to persons on all applicable restricted party lists (see e.g.

<http://www.bis.doc.gov/index.php/policy-guidance/lists-of-parties-of-concern> and

http://eeas.europa.eu/cfsp/sanctions/consol-list_en.htm, and

<https://www.meti.go.jp/policy/anpo/englishpage.html>)

where prohibited, or to use these items in activities involving missiles or unmanned air vehicles, nuclear explosive devices or nuclear propulsion projects, chemical or biological weapons which are regulated as WMD (Weapons of Mass Destruction), or any other prohibited end-use. (see e.g.

<https://www.bis.doc.gov/index.php/documents/regulation-docs/418-part-744-control-policy-end-user-and-end-use-based/file>)

Exporting this product (Relating telecommunications regulations)

- Wireless communication module is incorporated in the instrument. Use of this technology must be compliant with telecommunications regulations of the country where the instrument is being used. Even exporting the wireless communication module may require conformity with the regulations. Contact your local dealer in advance.

Exceptions from Responsibility

- The manufacturer, or its representatives, assumes no responsibility for any damage, or loss of profits (change of data, loss of data, loss of profits, an interruption of business etc.) caused by use of the product or an unusable product.
- The manufacturer, or its representatives, assumes no responsibility for any damage, or loss of profits caused by usage different to that explained in this manual.
- The manufacturer, or its representatives, assumes no responsibility for consequential damage, or loss of profits due to heavy rain, strong wind, high-temperature and humidity, or storing or use of the product under unusual conditions.
- Product failures caused by rebuilding are out of warranty.
- Cautions and warnings included in this manual do not cover all the possible events.

3. LASER SAFETY INFORMATION

The instrument is classified as a class 1 Laser Product according to IEC Standard Publication 60825-1 Ed.3.0: 2014 and United States Government Code of Federal Regulation FDA CDRH 21CFR Part 1040.10 and 1040.11 (Complies with FDA performance standards for laser products except for deviations pursuant to Laser Notice No.56, dated May 8, 2019.)

Warning

- Use of controls or adjustments or performance of procedures other than those specified herein may result in hazardous radiation exposure.
- Follow the safety instructions on the labels attached to the instrument as well as in this manual to ensure safe use of this laser product.

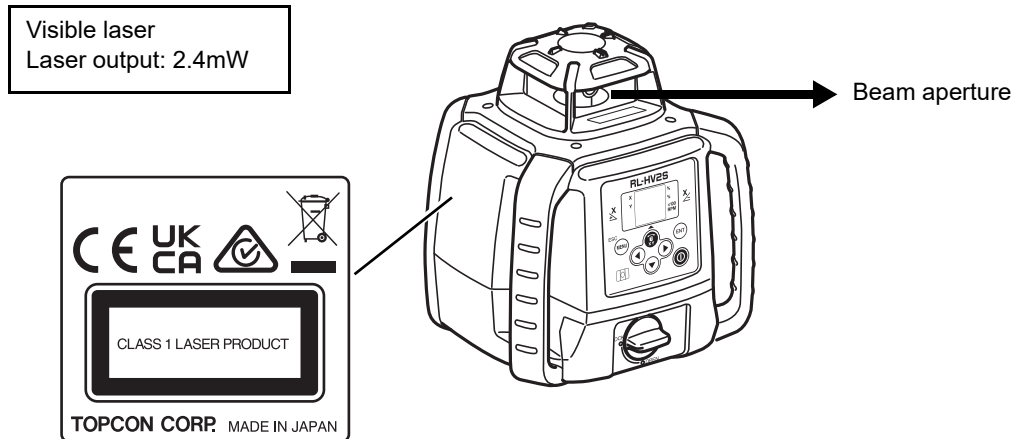

- Never intentionally point the laser beam at another person. The laser beam is injurious to the eyes and skin. If an eye injury is caused by exposure to the laser beam, seek immediate medical attention from a licensed ophthalmologist.

Caution

- Perform checks at start of work and periodic checks and adjustments with the laser beam emitted under normal conditions.
- When the instrument is not being used, turn off the power.
- When disposing of the instrument, destroy the battery connector so that the laser beam cannot be emitted.
- Avoid setting the instrument at heights at which the path of the laser may strike pedestrians or drivers at head height. Operate the instrument with due caution to avoid injuries that may be caused by the laser beam unintentionally striking a person in the eye.

4. PRODUCT OUTLINE

4.1 RL-HV

Parts of the instrument

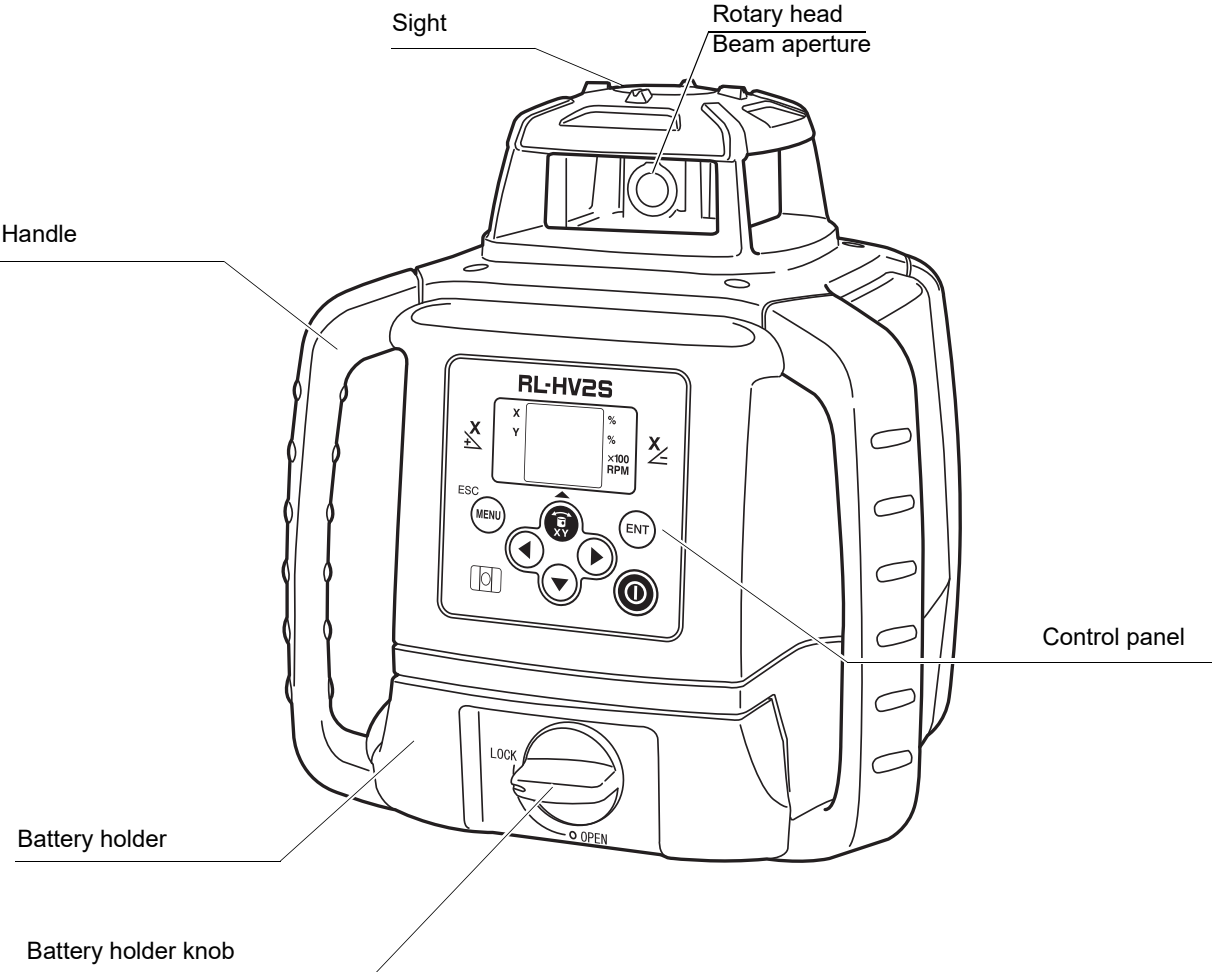

Control panel

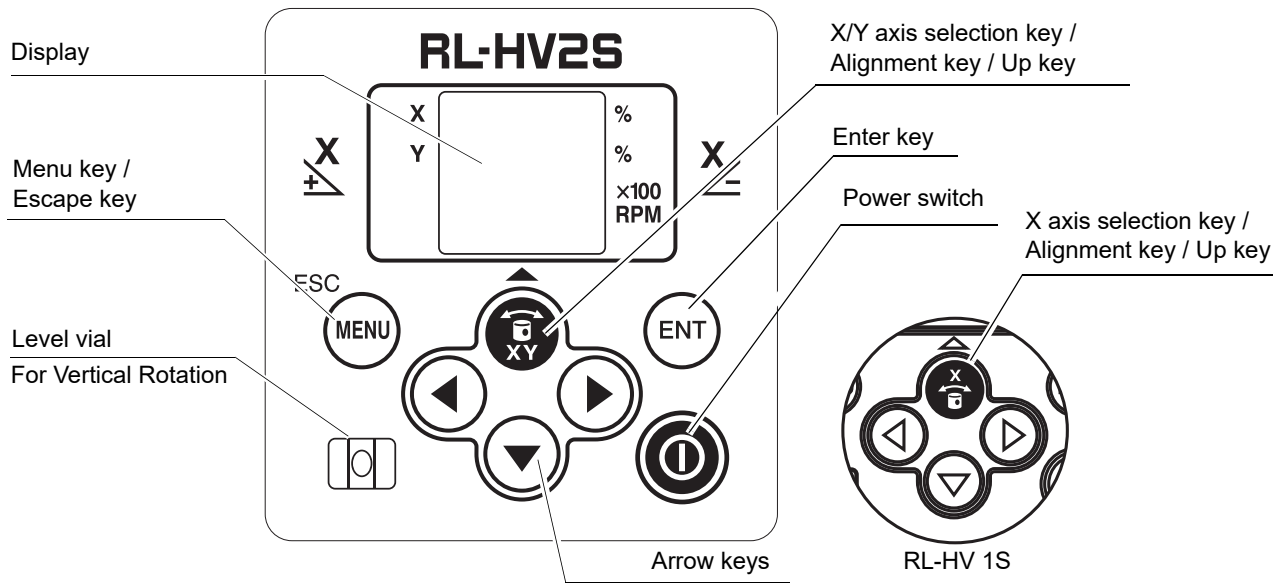

Key	Nomenclature	Function
	Enter key	End Operation of Data Input
ESC 	Menu/Escape key	Selects a menu item. Cancels input or escape to previous status.
1S 	X axis selection key/ Alignment key	Horizontal rotation: Changes to the grade setting screen for X axis. Vertical rotation: Changes to the Alignment Mode.
2S 	X/Y axis selection key/ Alignment key	Horizontal rotation: Changes to the grade setting screen for each axis. Vertical rotation: Changes to the Alignment Mode
	Arrow keys	The arrows indicate code selection, digit shift, and number input during grade setting, and designates direction during masking setting.
	Power switch	Turn the instrument ON or OFF.

Display

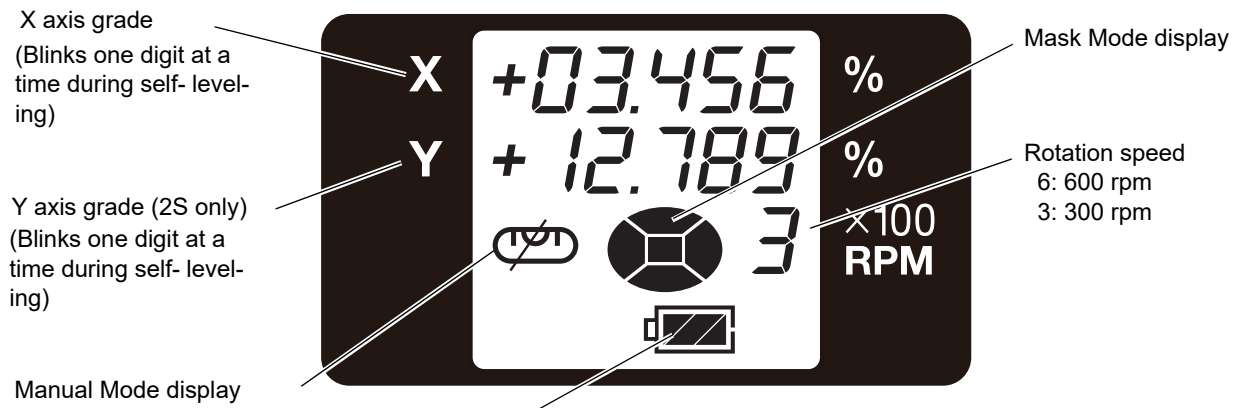

Battery remaining



Ample power for operation



Ample power for operation



Power remaining for operation*1)



Power remaining for operation
Near power depletion*2)

*1), *2) The laser speed will be 500 rpm.

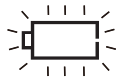

Power depletion, Laser will stop.

Dry battery type:

Rechargeable battery type:

Replace with new batteries.

Charge the battery.

4.2 Level Sensor LS-80X

Parts of the instrument

Power switch

The power switch turns ON or OFF by pressing.

Detective precision switch

Two detective precision options are available, normal precision ($\pm 2\text{mm}$) and high precision ($\pm 1\text{mm}$). By pressing this switch, the precision options are switched alternately. Confirm the precision choice by the indicator. (Normal precision is the default setting each time the sensor is turned on.)

Buzzer sound switch

Volume of the sensor buzzer can be alternately switched to Quiet/Loud/OFF by pressing the switch.

Indicator LS-80X Display

Locate the datum position "---" by moving the LS-80X up and down. Directional arrows and audio signals assist in locating the datum position as the laser strikes the beam receiving window. (Top of LS-80X is 40mm (1 9/16") from on-grade index for offset marking.) The indicators are located on front and back sides of the instrument.

Index

Beam receiving window

Turn the beam receiving window side towards RL-HV to detect the laser beam.

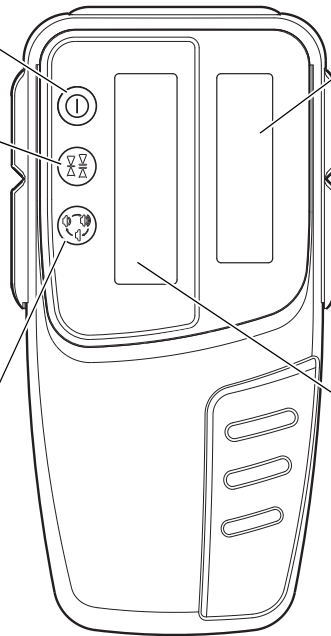

Auto-cut off function

The power will be turned off automatically if no laser beam is detected for approximately 30 minutes. (To turn on the level sensor, press the power switch again.)

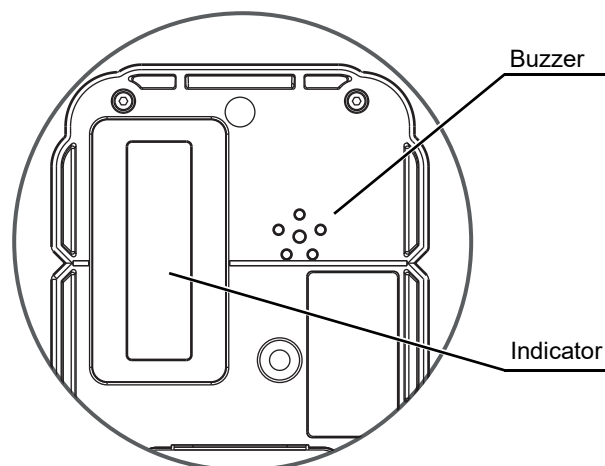

(Back side of the instrument)

Display

Height alert warning of rotating laser*1

A blink and a buzzer sound signifies that the height alert function of the RL-HV is operating.

Rotating laser battery warning*2



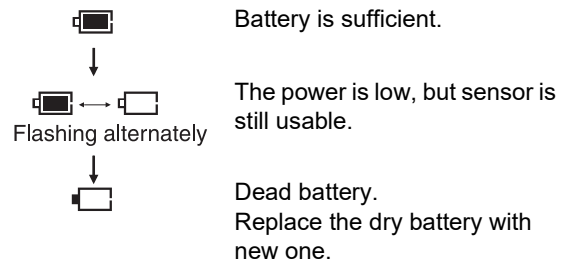
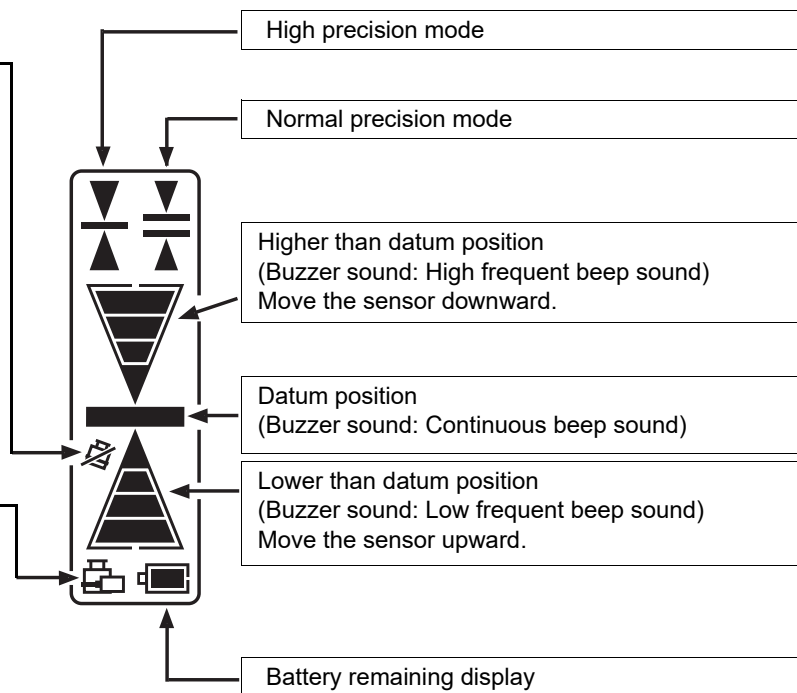









A blink shows that the RL-HV power is low.



Note

- The warning displays *1 and *2 are the functions that the LS-80X detects alarm signal from the RL-HV. The LS-80X can be canceled the alarm detection from the RL-HV. To be canceled the detection; Press the power switch while pressing the buzzer sound switch when powering on. The detecting function will start normally by pressing the power switch again.

Detective Range

Display	Precision
	 High $\pm 1\text{mm}$ (2mm width)  Normal $\pm 2\text{mm}$ (4mm width)
 	$\pm 5\text{mm}$ (10mm width)
 	$\pm 10\text{mm}$ (20mm width)
 	$\pm 15\text{mm}$ (30mm width)
 	more than $\pm 15\text{mm}$ (more than 30mm width)
 	Level sensor is moved upward or downward from laser beam.

5. USING THE BATTERY

Be sure to charge the battery fully before using it for the first time or after not using it for long periods.



- The charger will become rather hot during use. This is normal.
- Do not use or charge batteries other than those designated.
(Battery pack: BT-79Q AC/DC converter: AD-15E)
- Do not charge the battery just after charging is completed. Battery performance may decline.
- Recharging should take place in a room with an ambient temperature range of 10 to 40°C (50 to 104°F).
- Do not perform charging with others except the AC/DC converter AD-15E.
- For longer battery life, conform to the suggested charging time to the extent possible.
- The battery source will discharge when stored and should be checked before using with instrument.
- Do not recharge the battery when fully charged. Doing so will lower battery performance.
- Be sure to charge stored battery source every 3 or 6 months and store in a place at 30°C or below. If you allow the battery to become completely discharged, it will have an effect on future charging.
- Batteries generate power using a chemical reaction and as a result have a limited lifetime. Even when in storage and not used for long periods, battery capacity deteriorates with the passage of time. This may result in the operating time of the battery shortening despite having been charged correctly. In this event, a new battery is required.

5.1 Battery Charging

PROCEDURE

1. Select a power plug which will be fit to the shape of the power outlet to be used.

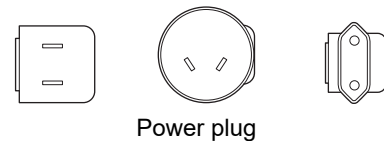

2. Install the selected power plug to the AC/DC converter as the right figure.

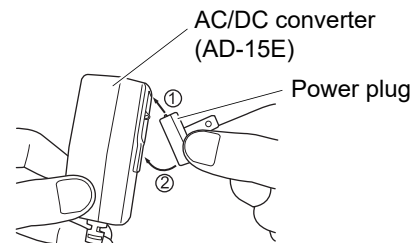

3. Connect the AC/DC converter into the charge port of the battery pack.

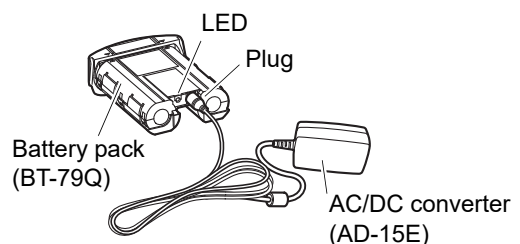

4. Plug the AC/DC converter into the wall outlet.
When charging starts, the LED is solid red. The LED is off when charging finished.
5. Unplug the AC/DC converter from the battery pack and disconnect the AC/DC converter power plug from the wall outlet



- Charging time:
BT-79Q: about 13 hours (at 20°C)
(Charging can take longer than the times stated above when temperatures are either especially high or low.)
- Charging lamp:

LED	Description
Red lamp lit	On charge
Off	Fully charged
Red lamp blinking slowly	Ni-MH battery pack protection feature is working automatically. Let the battery pack fall within its designated charging temperature range (10 to 40°C), unplug the AC/DC converter from the battery pack and then check the LED status. Solid red LED indicates charging has started again. Slow blinking red LED indicates the Ni-MH battery is still out of the charging temperature range. Wait for a while, unplug the AC/DC converter and then check the LED again. The instrument has a protection feature which works when the batteries are under a high or low temperature state. In such a case, charging will stop automatically to protect nickel hydride batteries.
Red lamp blinking quickly	The battery is not charged properly. Please contact your local dealer.

5.2 Installing/Removing the Battery

PROCEDURE Installing the battery

1. Insert the battery pack into the battery holder.

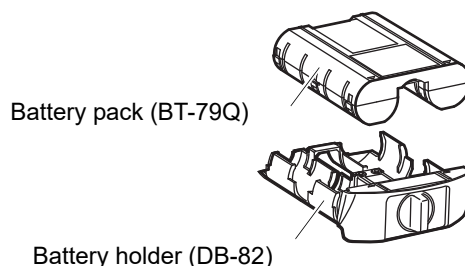

2. Insert the battery holder. Tighten the battery holder knob to "LOCK" side.

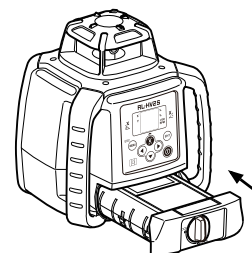

PROCEDURE Removing the battery

1. Remove the battery holder by turning battery holder knob to "OPEN" side.
2. Grasp the specified place on the battery holder, which is shown on the right, and remove the battery pack.



- It is possible to remove the battery pack from the battery holder and use the dry batteries.

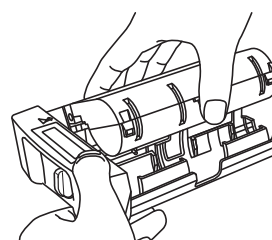

5.3 Using the Dry Batteries

■ RL-HV



- Replace all 4 dry batteries with new ones at the same time.
- Do not mix used and new dry batteries, and do not mix different types of dry batteries together.
- Generally, performances of dry battery deteriorate temporarily in low temperature, but recover in normal temperature.
- Dry batteries are sold separately.

Note

- It is possible to remove the dry batteries from the DB-82 battery holder and use the battery pack BT-79Q.

PROCEDURE Replacing the dry batteries

1. Remove the battery holder by turning battery holder knob to "OPEN".

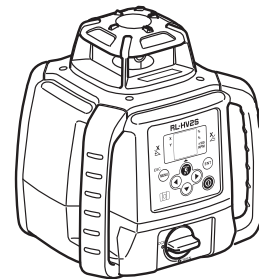

2. Remove the old batteries and replace with new four dry batteries (D alkaline batteries), matching [+] and [-] as shown in the figure.

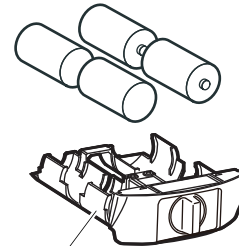

Battery holder (DB-82)

3. Insert the battery holder. Tighten the battery holder knob to "LOCK" side.

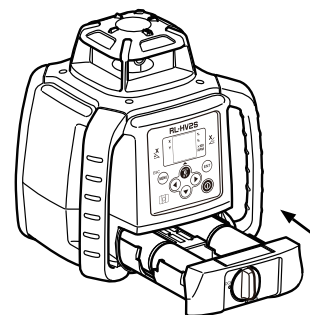

■ LS-80X

- When attaching the battery cover, make sure that the rubber packing inside the battery box is in the right place.
- Do not use a low dry battery. Switches or displays may not work correctly.
- Replace all 2 dry batteries with new ones at the same time.
- Do not mix used and new dry batteries, and do not mix different types of dry batteries together.
- Generally, performances of dry battery deteriorate temporarily in low temperature, but recover in normal temperature.
- Dry batteries are sold separately.

PROCEDURE Replacing the dry batteries

1. Push and slide the battery cover in direction of arrow 1.
2. Open the cover in direction of arrow 2 to remove it.
3. Remove the old dry batteries and replace with new two dry batteries (AA alkaline batteries), matching [+] and [-] as shown in the figure.
4. Insert the tab of the battery cover, and push the cover down until it snaps into place.

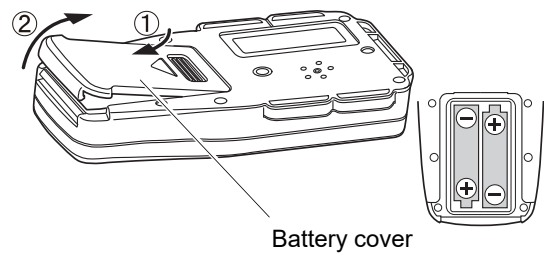

6. BASIC OPERATION



- It may take some time for the laser to be emitted after the rotary head rotates, but this is not a malfunction of the instrument.

6.1 Setting up the instrument

■ Horizontal Rotation

1. Set the instrument to the tripod or smooth surface.
2. Press power switch (ON).
Self-leveling will begin. After the self-leveling, the laser beam will emit horizontally.

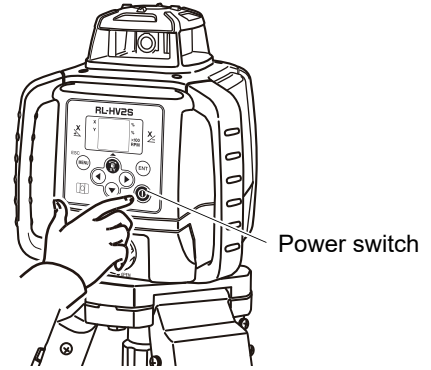

The RL-HV automatically levels within the range of $\pm 5^\circ$ as shown on the right. It is also possible to set grade for the RL-HV in the direction of 2 axes (1S: X axis direction only).
☞ "7.1 Setting Grades" on how to set grade.

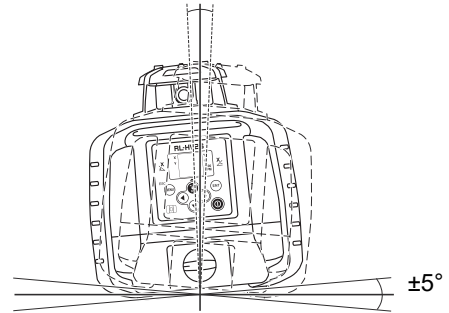

3. Press power switch on the LS-80X (ON).
4. Select the precision mode by pressing the detective precision switch.
☞ "4.2 Level Sensor LS-80X"
5. Locate the datum position "---" by moving the LS-80X up and down.

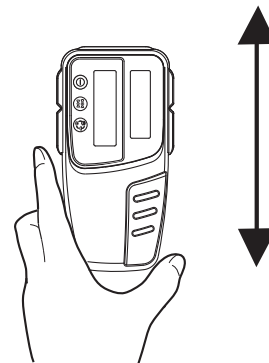

6. Mark the position of index.
 Top of the level sensor is 40mm [1 9/16"] from index for offset marking.

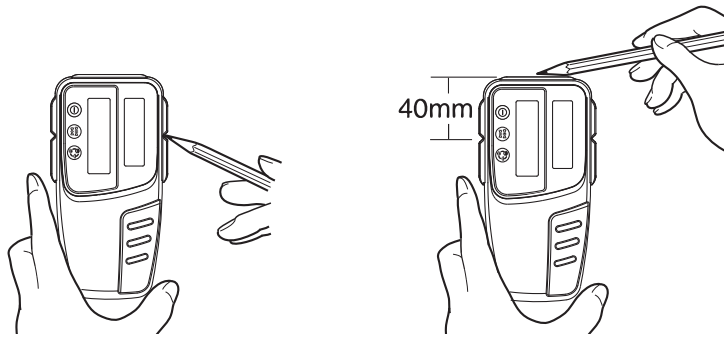

■ Example Operational

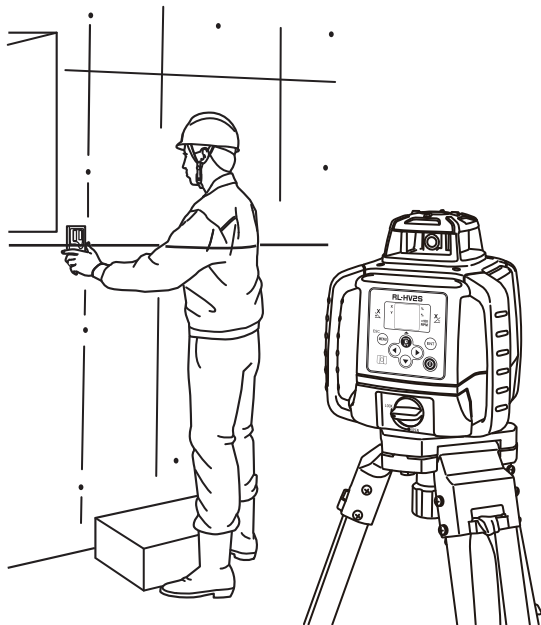

Install the LS-80X on a staff in the manner shown below.

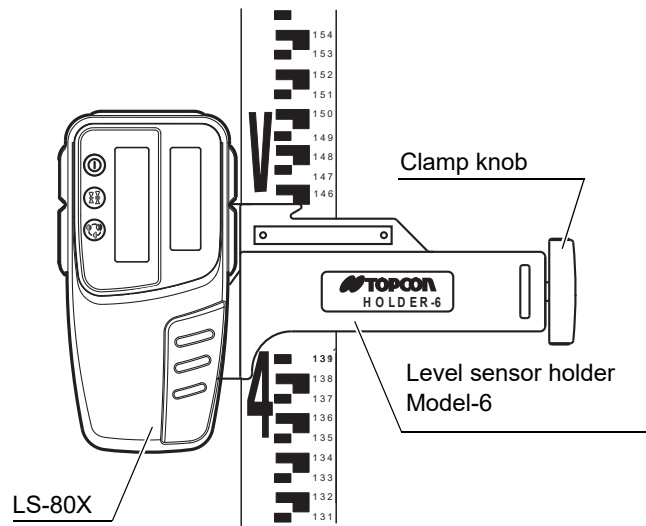

■ Vertical Rotation

1. Install the RL-HV on to the tripod and set so that the bubble is at the center of the vertical rotation circular level vial.

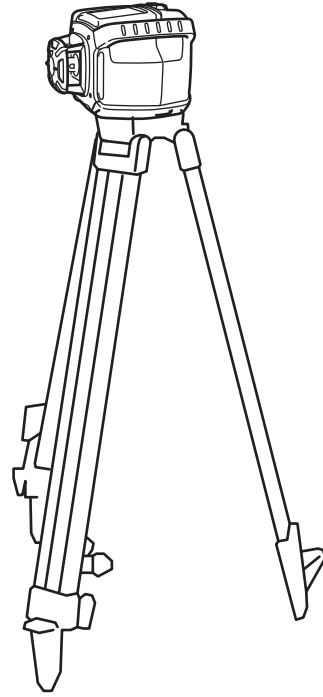

2. Press power switch.

When self-leveling is complete, the laser beam will emit vertically.

 For manual line control, see "7.2 Line Control (manual vertical beam alignment)"

6.2 Height Alert Function

When the instrument system detects a shock, this function informs the operator of it.

- When the instrument's installation status (height) is sharply changed by the contact of the operator or the like, this function stops self-leveling to keep the operation accuracy and informs the operator of the situation.
- After 10 minutes has passed since the self-leveling function was activated and the laser beam was emitted, this function works.
- The height alert function will not operate while setting the dual axes grade in the Matching Mode, or Manual Mode.

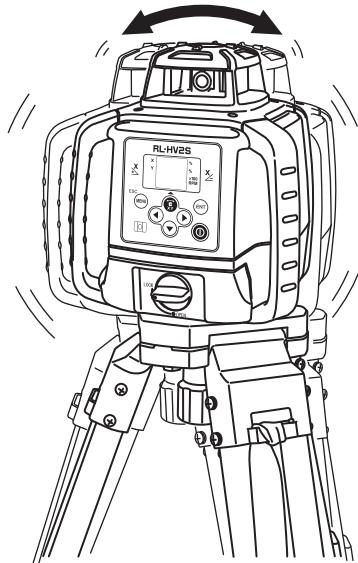

Shock is given to the instrument.

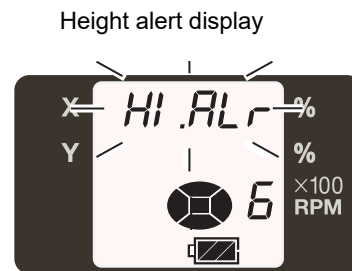

Blinking

 For more information about Height Alert ON/OFF, refer to "8.4 Height Alert ON/OFF"

PROCEDURE How to rest

1. Turn off the power switch.
2. Check whether the instrument is installed correctly.
3. Turn on the power switch. Self-leveling starts again. After self-leveling is finished, the laser beam is emitted.
4. Make sure that the laser beam is set at the correct height. Then, restart the operation.

6.3 Bluetooth Connection

Using *Bluetooth* communication, RL-HV can be remotely controlled by devices such as iPhone and Android. The control application "Laser Manager" would be better installed on your device in advance.



- *Bluetooth* function may not be built in depending on telecommunications regulations of the country or the area where the instrument is purchased. Contact your local dealer for the details.
- When connected with a device, the connection is held until the time mentioned below.
 - When canceling the connection from the device;
 - or
 - When pairing is performed with any other device.
- If RL-HV is not displayed during the pairing search in Laser Manager, please complete pairing on the OS. After that, please do pairing again by Laser Manager.
- When pairing with some instruments on Laser Manager, *Bluetooth* connection between instrument and Laser Manager may take some time. Please remove unnecessary instruments from *Bluetooth* connection history list on Laser Manager.
- After disconnecting *Bluetooth* by Laser Manager, the instrument icon may not be displayed on the search screen. Please wait for a while and re-enter the *Bluetooth* connection screen again.

■ Installing Laser Manager

There are two ways to install Laser Manager:

- Scan the QR code according to the instructions of the included "Laser Manager guide".
- Search for "Laser Manager" on the App Store or Google Play.

For details on App Store and how to install this application, see the Apple support home page (<https://support.apple.com>).

For details on Google Play and how to install this application, see the Google support home page (<https://support.google.com>).

PROCEDURE Communication between the RL-HV and your device

1. Turn on the RL-HV.
The RL-HV automatically enters the standby state for *Bluetooth* connection.
2. Turn on "*Bluetooth*" on your device.
 - For details, see the instruction manual of the device you are using.
3. Tap the icon on your device to start up Laser Manager and connect to the RL-HV.
 - About the pairing method, see the instruction manual of the device you are using.

7. APPLIED OPERATION

It is possible to set grades for the laser beam and various functions from the menu screen.



- It may take some time for the laser to be emitted after the rotary head rotates, but this is not a malfunction of the instrument.

7.1 Setting Grades

There are two methods to set grades on the laser beam: 1) direct entry of the grade values for the X axis (1S) / X and Y axes (2S), and 2) matching to set grades on laser beam according to the slope of the ground on site.

Grade can be set in both axes, X and Y (2S)/ in the X axis (1S), as shown below.

Grades can be set in the range indicated below.

Single axis

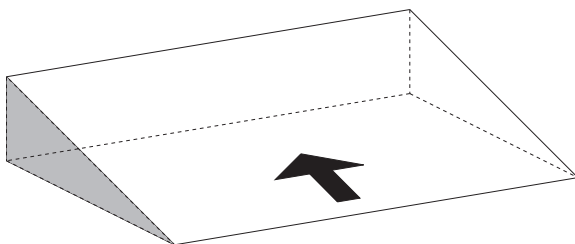

Grade range:
X: -15% to +15%
or
Y: -15% to +15% (2S only)

Dual axes (2S only)

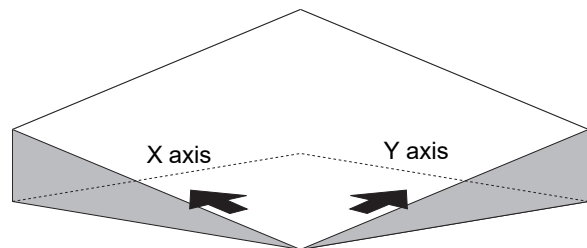

Grade range:
X: -15% to +15%
Y: -15% to +15%

Grade axes and axis symbols are as shown in the diagram below.

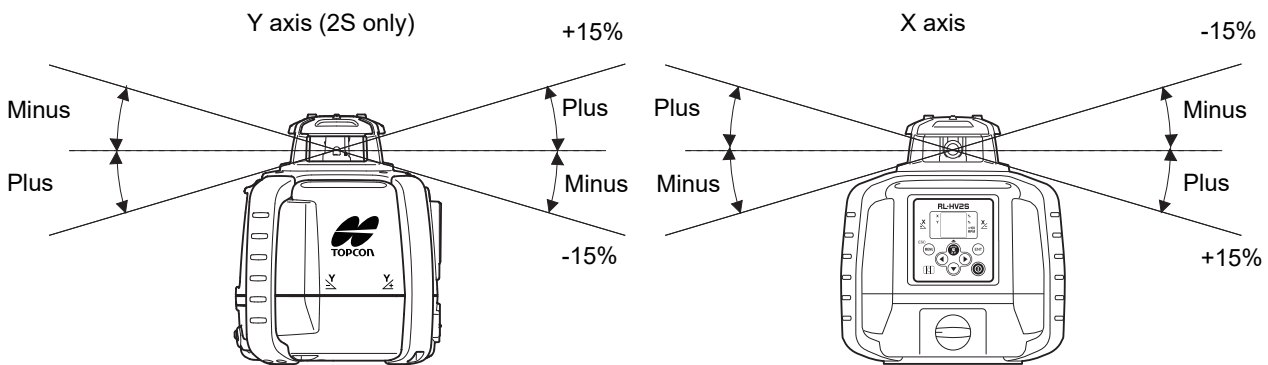

On the tripod whose head is horizontally placed, grades will automatically level to approximately $\pm 8\%$. When setting larger grades, tilt the RL-HV towards the direction of the slope to maintain within the self-leveling range. When exceeding the self-leveling range, the error message "Exceeding leveling range" will be displayed.

☞ "9. ERROR DISPLAYS"



- If you set grades by placing the RL-HV in a place where temperature suddenly changes, let the instrument stand for about 10 minutes to allow it to adjust to the temperature prior to actual use.



When temperature changes 5°C or more after setting a grade, temperature difference is detected and the grade is corrected automatically. During auto correction, laser will stop temporarily (and [AUTO CALIB] will be displayed). When auto correction is completed, the display will return to the grade setting, and after self-leveling, laser will emit.



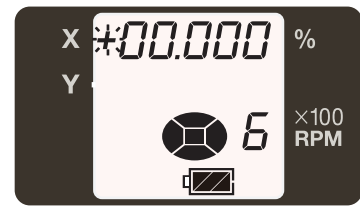

■ How to set grades (In case of 1S)



1. When pressing the  key, the sign of X axis will start blinking.

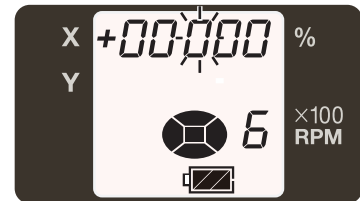

2. Press the   keys and select the sign (plus or minus).

3. Press the   keys to change the digit position.



4. Press the   keys to increase or decrease the value of the digit.



5. Press the  key to confirm the value.

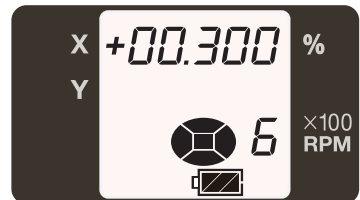

Resetting the grade value

1. When pressing the  key, the sign of X axis will start blinking.

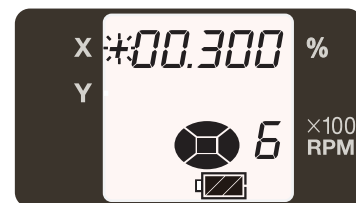

2. Press both the   keys simultaneously to reset the grade value.

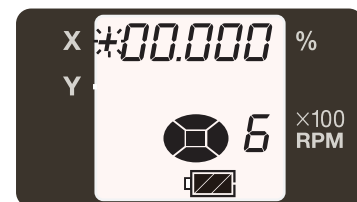

3. Press the  key again to set 0%.



■ How to set grades (In case of 2S)

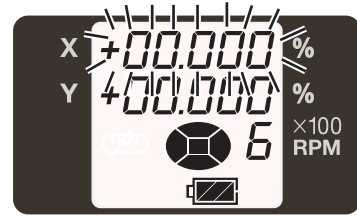

1. Press the  key and the X axis display will start blinking.
It is possible to enter the grade. (Pressing the key will toggle between the X axis and Y axis.)

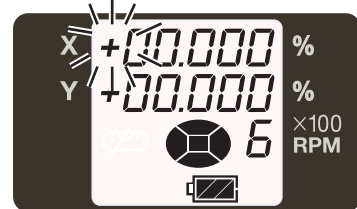



2. Press the  key.



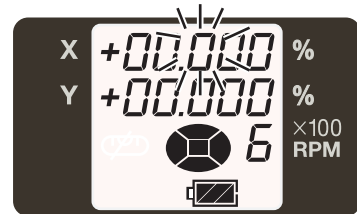

3. Press the   keys and select the mark (plus or minus).

4. Press the   keys to change the digit position.

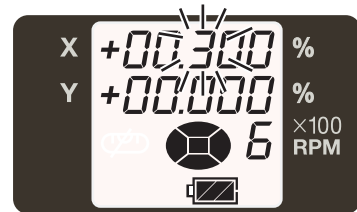

5. Press the   keys to increase or decrease the value of the digit.



6. Press the  key to confirm the value.

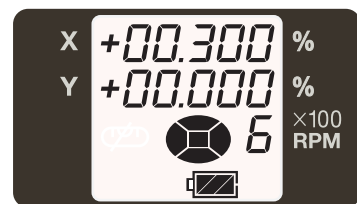

7. When setting the grade for the Y axis, press the  key. The Y axis display will start blinking.

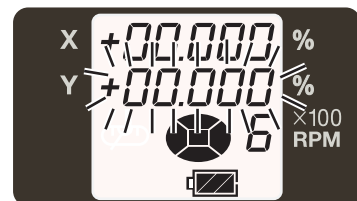

Set up the grade in the same manner as the X axis.

■ Example of how to set up

When setting grade, it is necessary to accurately set the RL-HV to the direction of grade setting. Below is an example of how to set grades to the accurate grade setting direction. (To work at X+3% (1S) / Y-3% (2S) grade surface to the base line)

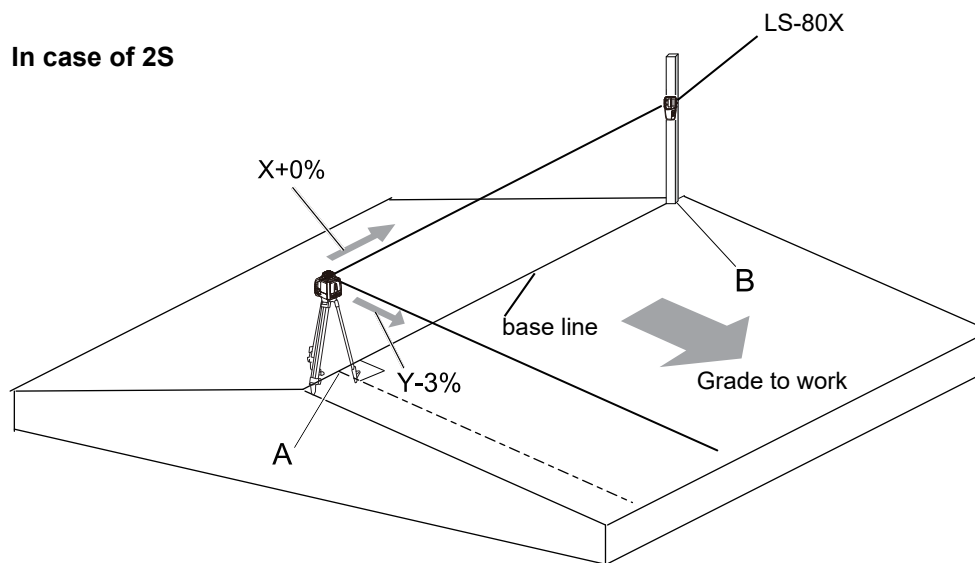
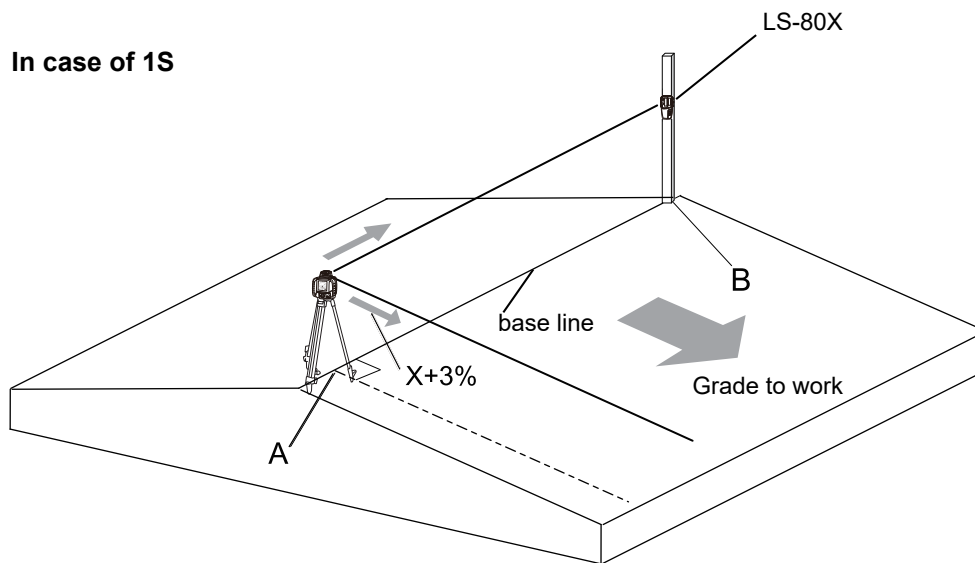

1. Set up the RL-HV on Point A of the base line using the plumb bob on the tripod.
2. Using the sight at the upper section of the RL-HV, adjust the direction on top of the tripod and roughly align the Y+ (1S) / X+(2S) direction to Point B on the standard axis.



3. Horizontally rotate the laser beam of the RL-HV. (1S: X+0.000% / 2S: X+0.000%, Y+0.000%)
4. At Point B adjust the height of the LS-80X installed on a pole, align the standard position of the LS-80X with the laser beam and fix.
5. Set the RL-HV at X+3.000% grade (1S) / at X+0.000% and Y-3.000% grades (2S).
6. Align the RL-HV direction on top of the tripod so as to have the laser beam in the ongrade position of the LS-80X in step 4.



- Do not change the height of the LS-80X installed on the pole. If the height of the RL-HV is changed, return to step 3 and redo the adjustment.

■ Matching Mode (Manual Slope)

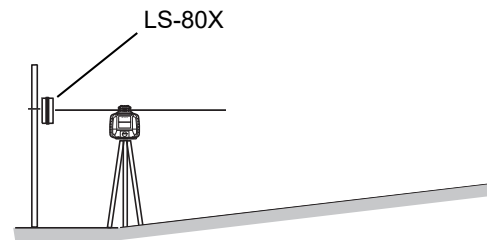

This mode is used to align the grades of the laser calibration to the worked grade.

1. Horizontally rotate the laser beam of the RL-HV set up at the standard height. (1S: X+0.000% / 2S: X+0.000%, Y+0.000%)
2. Adjust the height of the LS-80X installed on the pole and align the datum position of the LS-80X with the laser beam and fix.



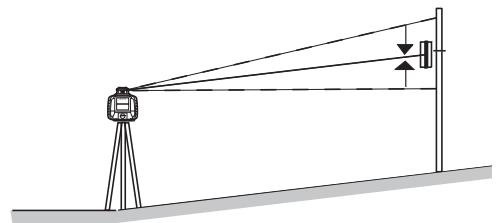



3. Set up the LS-80X in step 2 on the grade surface.
4. Using the sight, roughly align and set the position of the RL-HV on top of the tripod to the direction of the LS-80X.

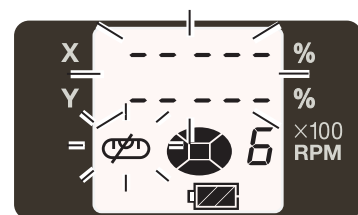
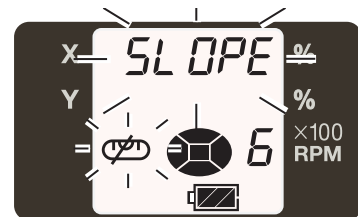

5. Press the  key.
6. Press the  key on the Matching Mode (SLOPE) selection screen.







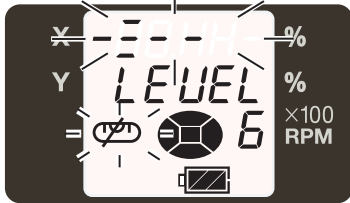
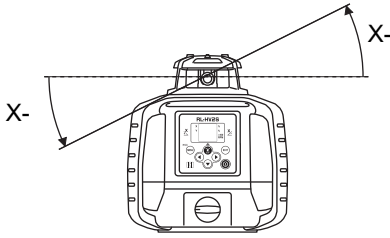

7. Confirm that self-leveling is complete and that the laser beam is emitting.
Press the arrow key (): To align with grade on the X- side) once in the desired direction to align grades, and the laser beam will continue to lean toward the direction of the key.
The arrow key cannot be used until self-leveling is complete and the laser beam starts emitting.
8. Pressing either of   key for the graded axis pressed in step 7 once again will stop laser beam grading.
If neither of arrow keys is pressed once more, the laser beam will return to the horizontal position.

9. Press   key to adjust the grade of the laser beam and align with the datum position for the LS-80X.
 The length of time the arrow key is pressed will change the speed at which the laser beam grades. (The speed will change from low to high speed.) For Y-axis grading, follow steps 7 to 9 using

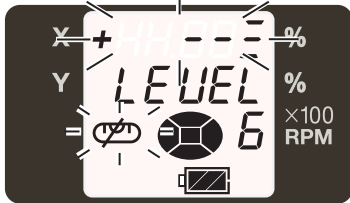
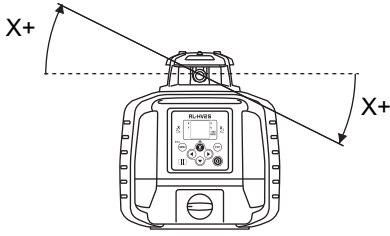
  keys.

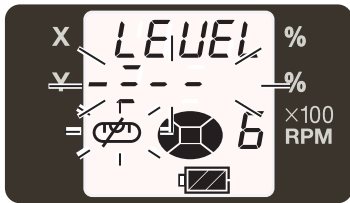
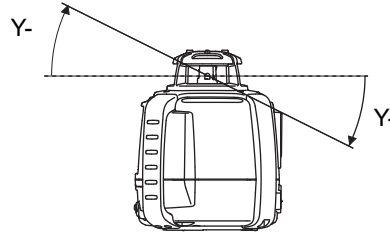
Grading direction of the laser beam during arrow key operation

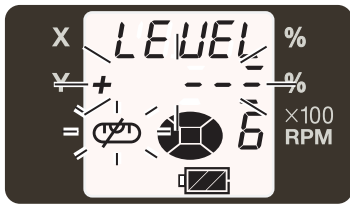
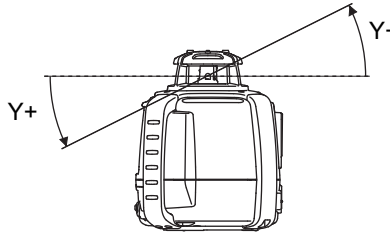
Key	Display*	Grading direction of the laser beam
		
		
		
		

*Display during arrow key operation

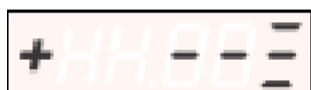



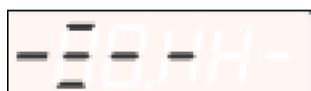

The laser beam is moving in the X (Y) + direction.



The laser beam is moving in the X (Y) - direction.

Note

- When the , ,  or  key is pressed, the laser beam will emit even if self-leveling starts.
- This mode can be used with "Laser Manager".

Display during Matching Mode



blinking : During matching mode.

It is possible to adjust the grade of the laser beam with arrow keys. When a certain amount of time has passed after the arrow key operation, the light that was blinking will remain lit. Grading cannot be adjusted when  is on.

- - - - -

: Shows the axis on which the grading is being adjusted.

SLOPE



: Shows the axis that is being graded. Self-leveling of the axis will not function at this time.



LEVEL

: Shows the axis whose grade is being automatically leveled horizontally. A blinking display indicates that self-leveling is being performed. The height alert function setting is valid at this time.

To readjust grading, return to step 5 and follow directions thereafter. However, skip steps 7 and 8 for an axis that is already graded.

Exiting the Matching Mode

When  is blinking : Press the  key to exit the Matching Mode. Press  key to set the grade value.

When  is lighted : Press the  key to set the grade value.

 "■ How to set grades (In case of 1S)"/"■ How to set grades (In case of 2S)"

7.2 Line Control (manual vertical beam alignment)

The laser beam can be moved to the direction of the key during vertical rotation.

Note

- Only the X axis can be moved.
- Allowable alignment range: $\pm 5^\circ$ (when the instrument is set up on the 0° surface)

1. Set the instrument.

If it is unable to visually confirm the laser beam on reference point A and B, set up the LS-80X on either of the points.

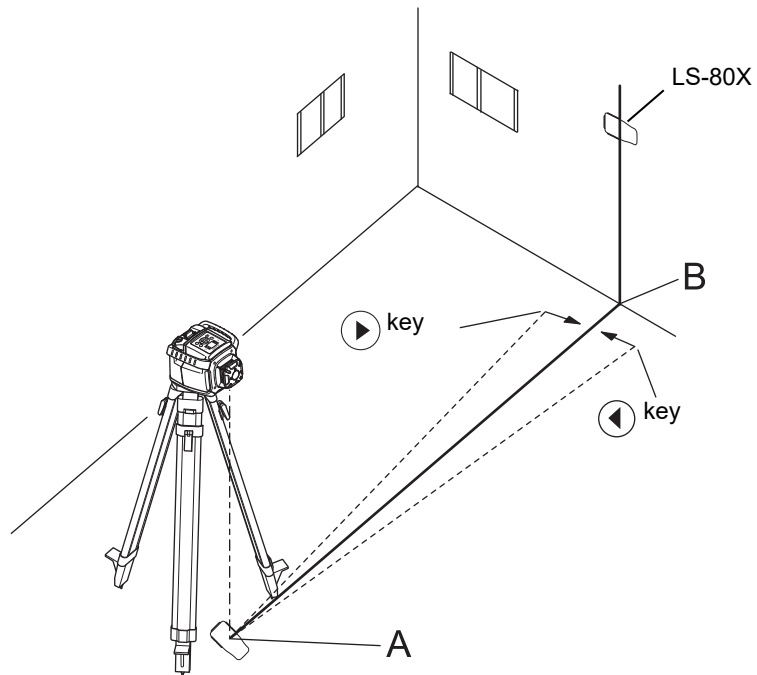



2. Press the power control key to turn unit on.
When self-leveling is complete, the laser beam will be rotate vertically.
3. Move and set the RL-HV to align reference point A and the laser beam.

Note

- Make sure that the RL-HV is set so that the bubble is at the center of the vertical rotation circular level vial on the control panel.



4. Press the  key to enter the line control mode.

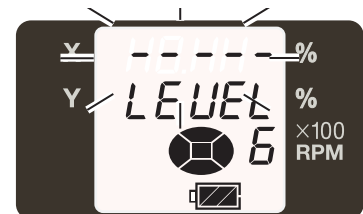

----- is blinking : During line control mode
It is possible to adjust the laser beam
with   key. When a certain
amount of time has passed after the key
operation, the light that was blinking will
remain lit. The laser beam cannot be
adjusted when the light is on.

LEVEL is blinking : Performing self-leveling in the vertical
direction.









5. Confirm that self-leveling is complete and that the laser beam is emitting.

Press either of   key once and the laser beam will move in the direction of the key to begin search.

The   key cannot be used until self-leveling is complete and the laser beam starts emitting.



6. Pressing either of   key pressed in step 6 again will stop the movement of the laser beam.

If neither of   key is pressed, the laser beam will return to the central area.

7. Press either one of the   key to move the beam right or left until it is precisely aligned to reference point B. The speed of laser beam movement will change according to the duration of time the   key is being pressed.

(The speed will change from low to high speed.)

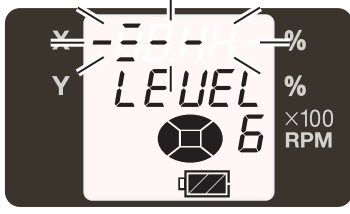
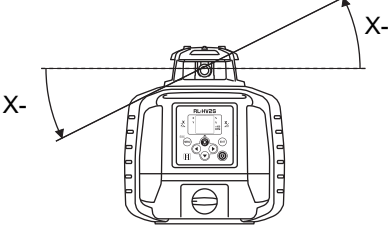
Direction of laser beam movement when operating key

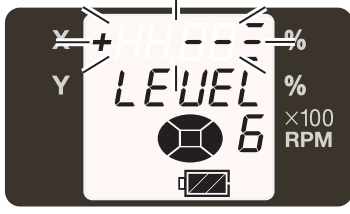
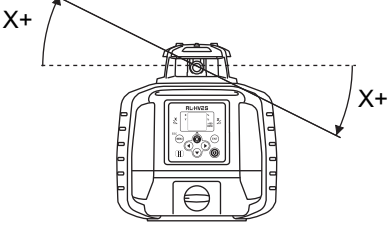
Key	Display*	Direction of laser beam movement
		
		

 *Display during arrow key operation

When readjusting with line control, return to step 4 and follow directions thereafter. In such a case, however, skip steps 5 and 6.

Note

- During the vertical rotation or the manual line control, the laser beam will emit even if self-leveling starts.
- This mode can be used with "Laser Manager".

8. CHANGING THE SETTINGS

After pressing the key, pressing the or key will change the menu items and setting can be performed for the functions listed below.

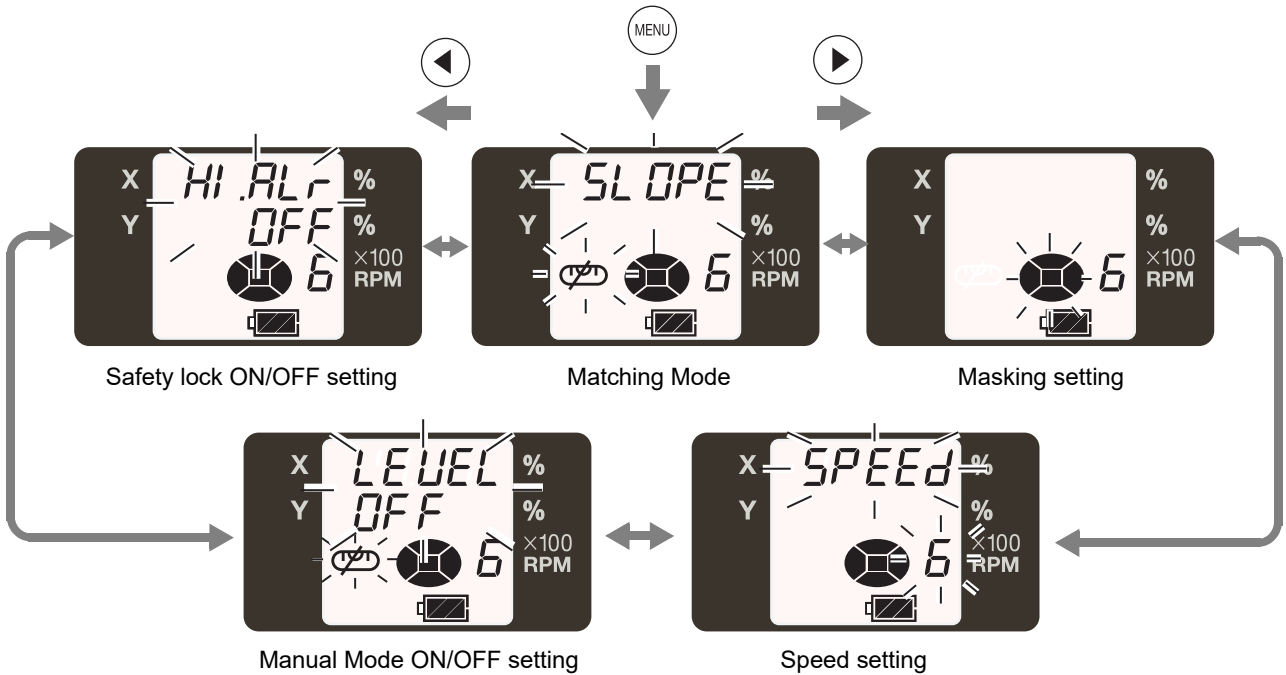

For Matching Mode, see "■ Matching Mode (Manual Slope)"

8.1 Masking (Laser beam shutter) setting

Depending on the status of the location where the instruments are used, laser beam emission to unnecessary direction can be shut off.

1. Press key to display the menu screen.
2. Use the key to position on the Mask display and press the key.
3. Select the direction you desire to mask using the arrow keys. Each press repeats mask activating/releasing.

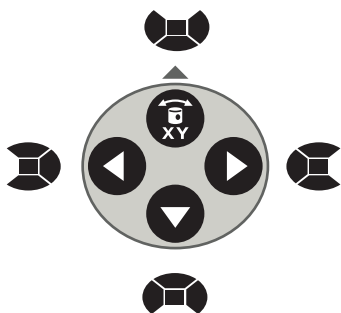
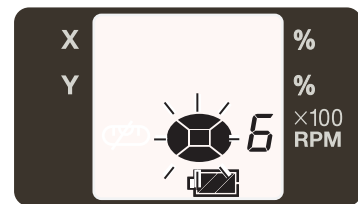

Arrow keys and masking setting directions

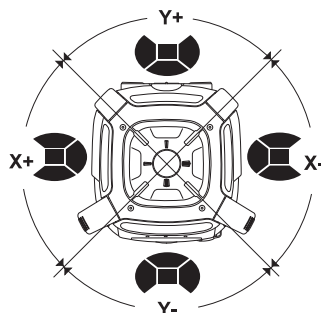

RL-HV upper surface diagram and masking directions



The state when masking is not activated. (Laser beams are emitted to all directions.)

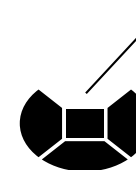

Displays the masking direction



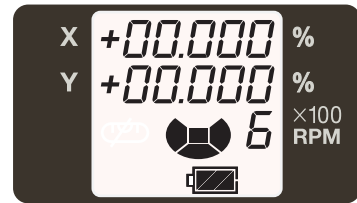

The status in which the Y+ direction is masked. (Laser beam is shut off in the Y+ direction.)

4. When desired masking is displayed, press the  key to finish.





8.2 Speed setting

The rotary head speed can be set to 600 or 300 R.P.M.

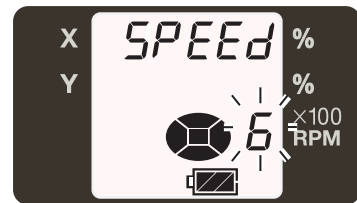
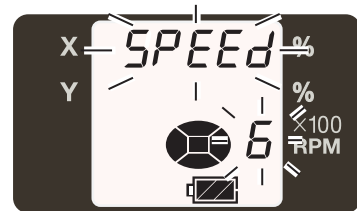
1. Press  key to display the menu screen.
2. Use the   key to select the rotary head speed (SPEED) and press the  key.



3. When the rotary head speed selected using the   keys, press the  key to finish.

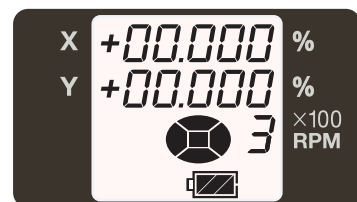
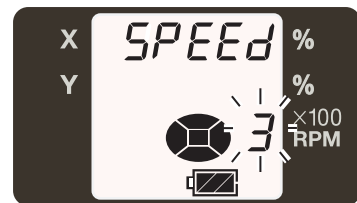





8.3 Manual Mode ON/OFF setting



Self-leveling function can be canceled and switched to Manual Mode.

Self-leveling OFF (LEVEL OFF) : After self-leveling is complete, the self-leveling function will stop. (Manual Mode)

Self-leveling ON (LEVEL ON) : Self-leveling function will be effective at all times.

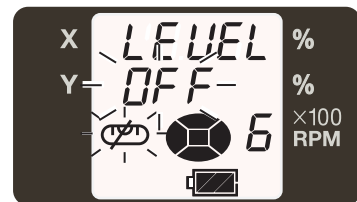
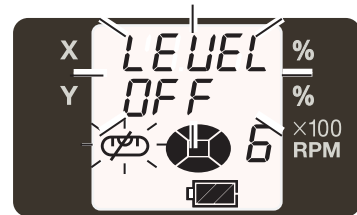
1. Press  key.
2. Press the  or  key to select self-leveling (LEVEL), and press the  key.







3. Press the  or  key to select ON or OFF and press the  key. Setting is complete.





8.4 Height Alert ON/OFF

☞ "6.2 Height Alert Function"

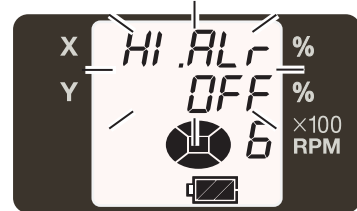
1. Press  key.
2. Press the  or  key and select Safety Lock ON/OFF (HI.ALr), and press the  key.



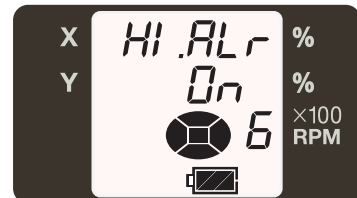
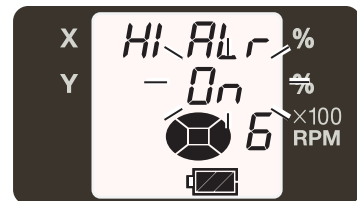

3. Press the  or  key and select ON or OFF, and press the  key. Setting is complete.



To shift to other modes, press the  key.

9. ERROR DISPLAYS

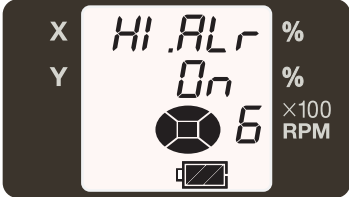
If an error is displayed, follow the procedures shown below.

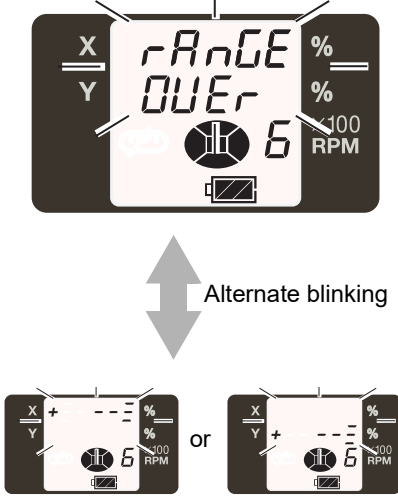
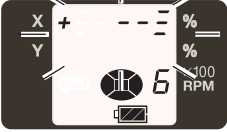
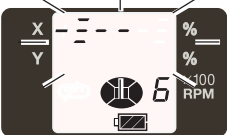
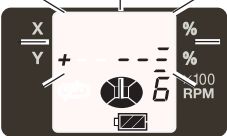
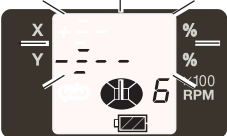
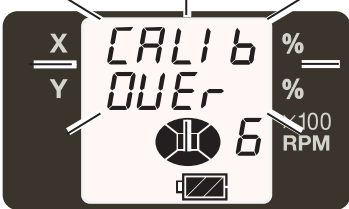
Error Display	Description/Countermeasure
	<p>The Height Alert Function is working.  "6.2 Height Alert Function"</p>
	<p>RL-HV setting exceeds the leveling range.</p>  Reset tilting to the direction to raise the X+ side.  Reset tilting to the direction to raise the X- side.  Reset tilting to the direction to raise the Y+ side.  Reset tilting to the direction to raise the Y- side.
	<p>Exceeding the adjustment range. Turn the power of the RL-HV off, turn on the power back again and readjust.</p>
<p>E-05</p>	<p>Turn the power for the instrument off, and then turn it back on.</p>
<p>E-56</p>	<p>Wireless function error for the RL-HV. Turn the power for the instrument off, and then turn it back on.</p>
<p>E-65</p>	<p>Internal transmission error for the RL-HV. Turn the power for the instrument off, and then turn it back on.</p>
<p>E-70's</p>	<p>Slope function error. Turn the power for the instrument off, and then turn it back on.</p>
<p>E-80's</p>	<p>Leveling incomplete. Turn the power for the instrument off, and then turn it back on in stable locations.</p>
<p>E-99</p>	<p>Internal memory error for the RL-HV. Turn the power for the instrument off, and then turn it back on.</p>

• If error code remains after trying countermeasures above, contact your local dealer.

10. CHECK AND ADJUSTMENTS

Please perform check and adjusting regularly. First check, and then make adjustments accordingly.

10.1 Check and Adjust Horizontal Rotation

■ Horizontal Rotation Grade Error

PROCEDURE Checking

1. Set up tripod approximately 50 meters away from a wall, and set the instrument on level with the X- facing the wall.

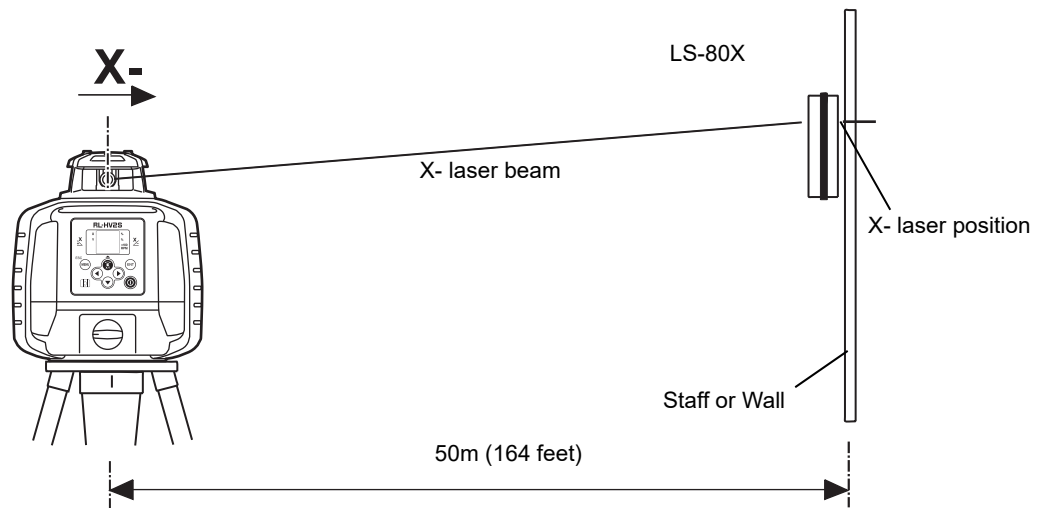
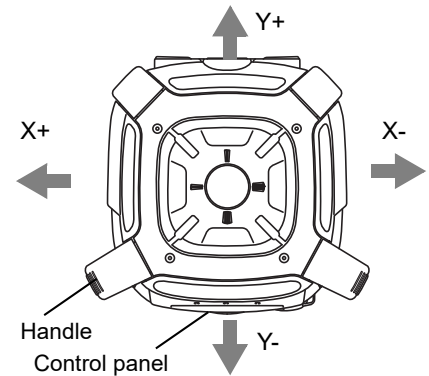

2. While pressing the  key, turn on the power. (Only the RL-HV is operable).
[CaLlb] will blink on the X axis screen. *1)

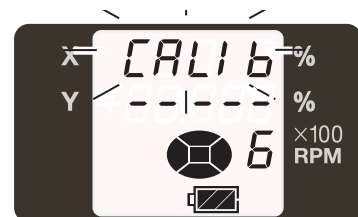

3. Press the  key.

The screen will be in the X-axis check and adjusting mode.
Self-leveling on the RL-HV is complete and the laser will emit.

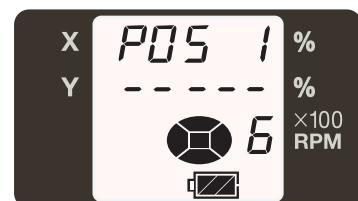

4. Turn the LS-80X to the high precision mode.

5. Detect the center of the laser beam on the wall with the LS-80X and mark it. (X1)

6. Press the  key.

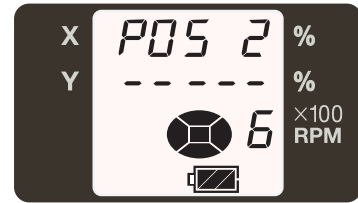

7. Loosen the centering screw and rotate the RL-HV 180°, and tighten the screw to secure. The RL-HV X+ surface will face the wall. When rotating the RL-HV, ensure that the instrument height is not misaligned.

The RL-HV self-leveling is complete and the laser will emit.

8. Detect the center of the LS-80X laser beam on the wall and mark (X2).

If the difference in height of the two laser beam marks (X1 and X2) is less than 5 mm, no adjustment is required. Turn off the power. If the difference is more than 5 mm, follow adjusting steps for horizontal rotation.

 "PROCEDURE Adjusting"

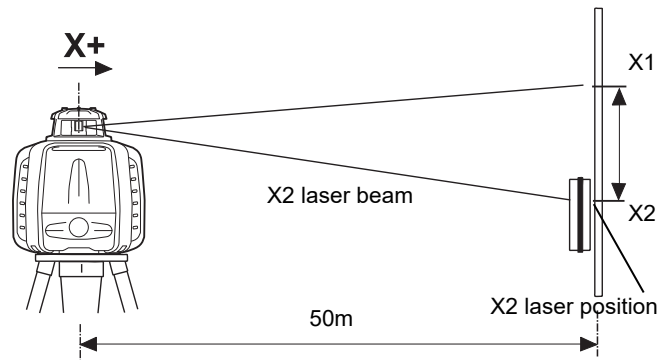

9. Perform check on the Y axis after the adjustment for the X axis is complete.

When checking and adjusting the Y axis direction, press the  key.

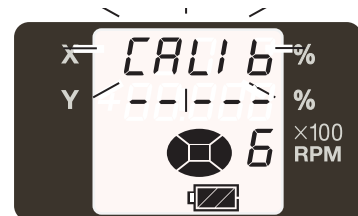

Press the  key.

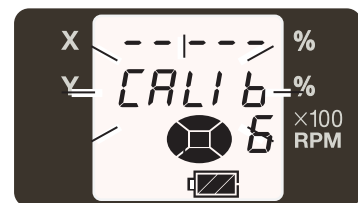

The screen will switch to the Y axis check and adjusting mode.

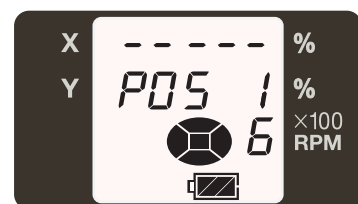

• A difference between X1 and X2 is more than 40 mm ($\pm 90^\circ$), it is outside of the adjustment range. Contact your local dealer.

PROCEDURE Adjusting

1. According to step 8 of the horizontal rotation check, press the ◀ ▶ keys* to move the laser beam between X1 and X2.

When adjusting the Y axis direction, press the  ▼ keys.

 *Display during arrow key operation

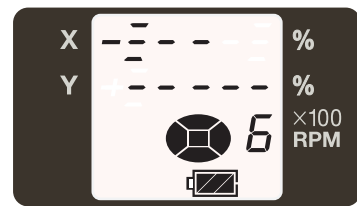

OR

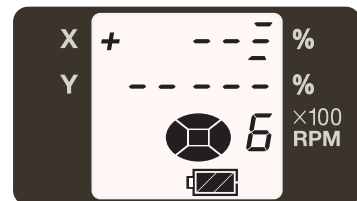

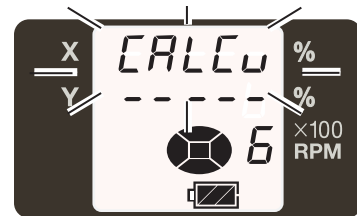

2. Press the  key.

RL-HV is calculating the correction value. Do not touch the RL-HV until [End] is displayed. (If you touch it, you will need to readjust.)

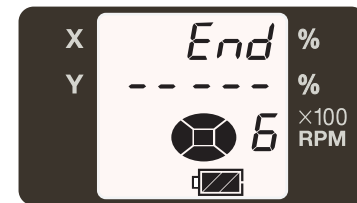

- Adjustment for X axis is complete.
Turn off the power.



- Exceeding the range of adjustment.
 "9. ERROR DISPLAYS"

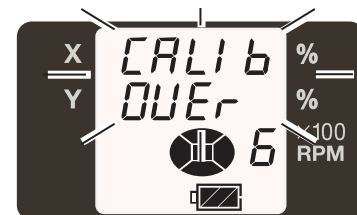

■ Horizontal Rotation Cone Error



- Perform the following check after completing the check for "■ Horizontal Rotation Grade Error".

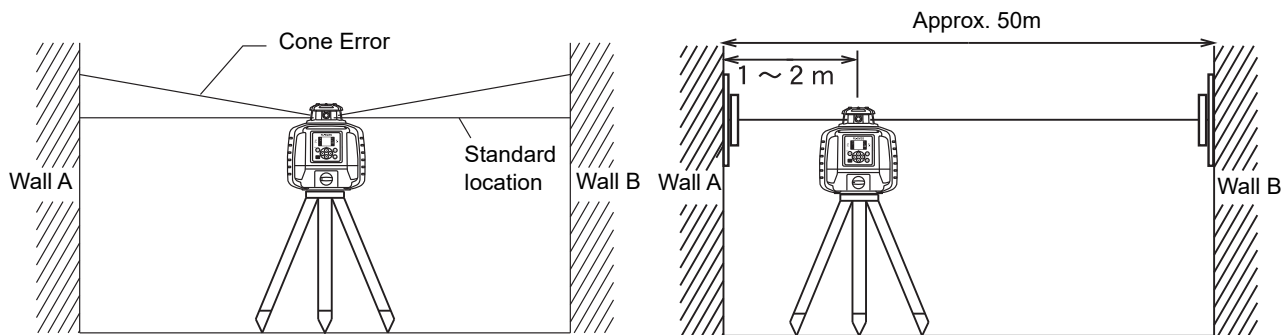

1. Set up the laser centered between two walls approximately 50 m (164 ft) apart. Orient the instrument so one axis, either X or Y, is facing the walls. Grade should be set to 0% in both axes.
2. Locate and mark the position of the RL-HV beam on both walls using the LS-80X.
3. Turn off the RL-HV and move the RL-HV closer to wall A (1 m to 2 m / 3 ft to 6 ft). Do not change the axis orientation of the RL-HV. Turn the RL-HV on.
4. Again locate and mark the position of the RL-HV beam on both walls using the LS-80X.
5. Measure the distance between the first and second marks on each wall.

If the difference between each set of marks is less than ± 5 mm ($\pm 7/32$ of an inch), no error exists.



- If the difference between [wall A]-side and [wall B]-side exceeds ± 5 mm ($\pm 7/32$ of an inch), contact your local dealer.

■ Grade Setting Error



- Perform the following check only after completing "■ Horizontal Rotation Grade Error" and "■ Horizontal Rotation Cone Error".

PROCEDURE Checking

1. Setup the X- side facing the staff as shown in the figure.
Securely position Nail 1 and Nail 2 exactly 30m apart.

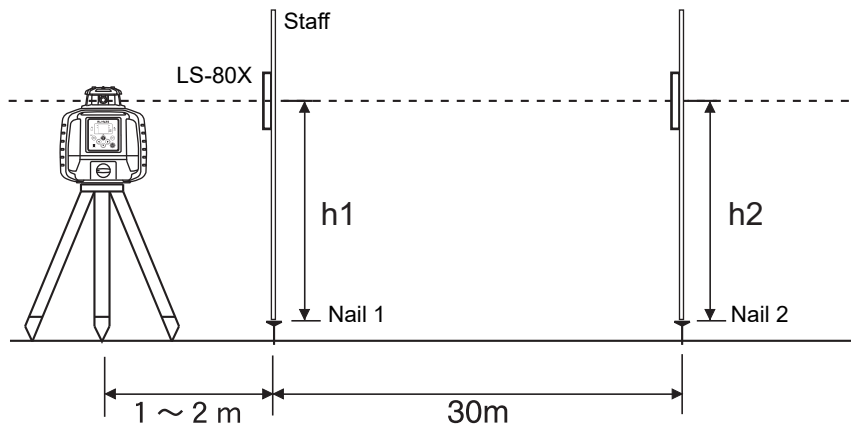

2. Turn on power for the RL-HV and verify the staff height of Nail 1 and Nail 2 at grade setting of 0% with LS-80X and record.
At this time the staff height for Nail 1 and Nail 2 should recorded as h1 and h2 (mm). Check the LS-80X is set at high7 precision.
3. Set X axis grade to +1.000%.
Align read the elevation of the laser beam in millimeters at Nail 1 and Nail 2. Designate these elevations as "h3" at Nail 1, and "h4" at Nail 2.

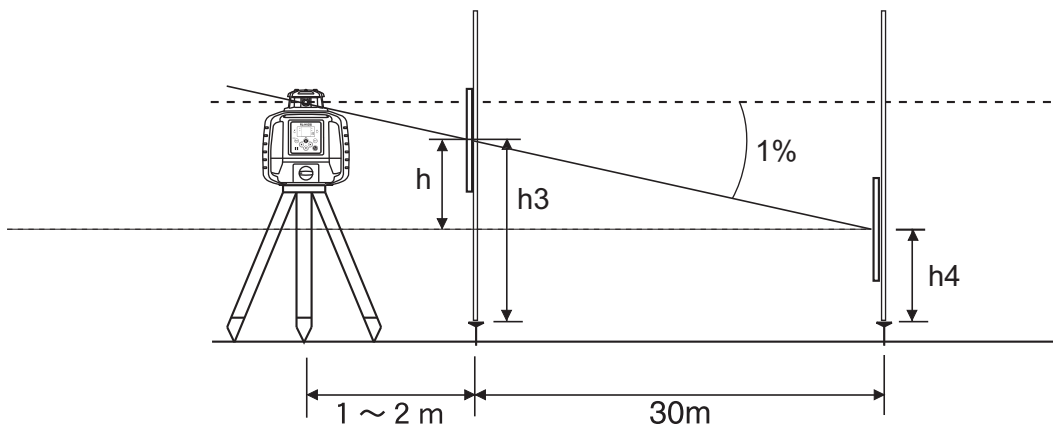

4. Using the elevation readings for h1, h2, h3 and h4, complete the equation below.

$$X(\%) = \frac{h}{30000(\text{mm})} \times 100 = \frac{(h2-h4)-(h1-h3)}{30000} \times 100$$

If the calculated result is the range of 0.990% - 1.010%, the instrument is normal.
If the calculated result for either axis is out of the range, contact your local dealer.
Repeat the procedure aligning the "Y" axis on the line created by Nail 1 and Nail 2.

10.2 Vertical Calibration



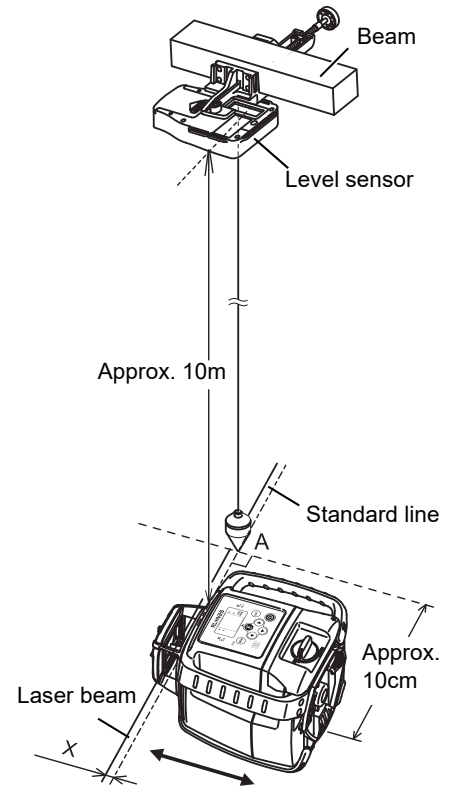

■ Checking Calibration

1. Turn on the power for the LS-80X and move into high precision mode.
2. Install the LS-80X on a beam 10 meters or higher above the floor, as shown in the diagram.
3. Hang the plumb bob from the LS-80X indicator to the floor (Point A).
4. Mark the standard line on the floor perpendicular to the direction of the beam where Point A crosses.
5. Set up the RL-HV for vertical rotation at the position shown in the diagram and turn on the power.
6. Maintain the level of the standard line on the floor and laser beam, and move the RL-HV to the direction of the arrow. Ensure that the laser beam is at the LS-80X indicator position (check with the buzzer sound from the LS-80X).
7. Measure the difference X between the standard line and laser beam.

If X is within 1 mm, no adjustment is required. If the difference exceeds 1 mm, move on to the next adjustment.



■ Vertical calibration and adjustment

1. While pressing the  key, press the  key.
2. Press the  key.
Move the RL-HV in the direction of the arrow to align the standard line and laser beam.
3. Press either the  key or the  key to align the laser beam with the LS-80X indicator position. (check with the buzzer sound from the LS-80X)

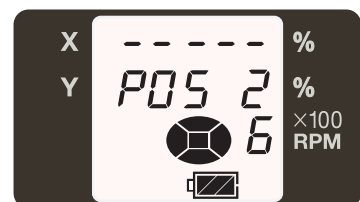
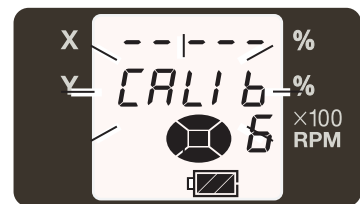

4. Press the  key.

The RL-HV is calculating the correction value.

Do not touch the RL-HV until [End] is displayed. (If you touch it, you will need to readjust.)

When the screen on the right is displayed, the adjustment is complete. Turn off the power.

 Note

• If [CALIb OVEr] is displayed:  "9. ERROR DISPLAYS"

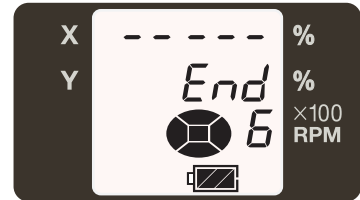
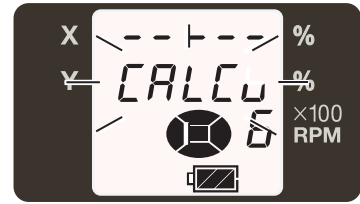

11. SPECIFICATIONS

Light source	Laser diode (Visible, 635 nm) Class1 (IEC60825-1 Ed. 3.0: 2014/FDA CDRH 21 CFR Part 1040.10 and 1040.11 (Complies with FDA performance standards for laser products except for deviations pursuant to Laser Notice No.56, dated May 8, 2019.))
Laser output	2.4 mW
Self-leveling range	Horizontal $\pm 5^\circ$ Vertical $\pm 5^\circ$
Accuracy	Horizontal $\pm 10''$ Vertical $\pm 10''$
Grade setting range	X: $\pm 15\%$ Y: $\pm 15\%$ (2S only)
Manual slope settable range	$\pm 5^\circ$ (When the instrument is installed on the 0° surface) The slope range is increased or decreased according to the tilt of the surface on which the instrument is installed.
Line control during vertical rotation	$\pm 5^\circ$ (When the instrument is installed on the 0° surface)
Rotational speeds	300/600 r.p.m (Changeable)
Operating range	Diameter Approx. 2 to 800 m or more (Rotational speed 600 r.p.m/When using LS-80X)
<i>Bluetooth</i> wireless communication* ¹	
Version	<i>Bluetooth</i> 5.0 (<i>Bluetooth</i> Classic / <i>Bluetooth</i> Low Energy)
Transmission method	FHSS
Modulation	GFSK
Frequency band	2.402 to 2.480GHz
<i>Bluetooth</i> profile	SPP, GATT(TOPCON Transfer Service)
Power class	Class 1.5
Usable range	Horizontal: 100m / Vertical: 20m (when placed vertically) (good communication condition)* ^{2, 3}
Authentication	Yes/No (selectable)

*1: *Bluetooth* function may not be built in depending on telecommunications regulations of the country or the area where the instrument is purchased. Contact your local dealer for the details.

*2: With instrument height to be more than 1.2m, no obstacles (like building structures, trees or vehicles) causing interrupting/reflecting radio wave, few sources of radio emissions/interference in the near vicinity of the instrument, no rain.

*3: Usage range could be shorter depending on specifications of *Bluetooth* device to communicate.

Power source	4xD size dry batteries (alkaline) Ni-MH battery pack BT-79Q (7000mAh)
Working duration at 20°C (68°F)* ⁴	
Dry batteries (alkaline)	120 hours
BT-79Q	65 hours
Battery (BT-79Q) Ni-MH rechargeable battery	
Nominal voltage	4.8V
Capacity	7,000mAh
Size	104(W) x 127(D) x 37(H) mm
Weight	690 g
AC/DC Converter (AD-15E)	
Input voltage	100 to 240 V AC, 50 to 60 Hz, 0.6 A
Output voltage	DC 9 V/2.0 MAX 18 W



Charging time at 20°C (68°F)*4	
BT-79Q	about 13 hours
Charging temperature range	10 to 40°C (50 to 104°F)
Storage temperature range	-20 to 70°C (-4 to 158°F)
Size (excluding cable)	74(W) x 43.5(D) x 35.3(H) mm
Weight	141 g
Dust and water resistance	IP66 (IEC 60529:2001)
Operating temperature range	-20 to 50°C (-4 to 122 °F)
Storage temperature range	-30 to 60°C (-22 to 140 °F)
Size	177(L) X 196(W) X 217(H) mm
Weight	about 2.6kg (with dry batteries) about 2.8kg (with BT-79Q)
Tripod screw	5"/8X11 threads for surveying instrument

*4: Figures will change depending on the operating environment including temperatures and observation conditions.

12. REGULATIONS

Region/ Country	Directives/ Regulations	Labels/Declarations
U.S.A.	FCC-Class B	<p>FCC Compliance WARNING: Changes or modifications to this unit not expressly approved by the party responsible for compliance could void the user's authority to operate the equipment.</p> <p>NOTE: This equipment has been tested and found to comply with limits for a Class B digital device, pursuant to Part 15 of the FCC Rules. These limits are designed to provide reasonable protection against harmful interference in a residential installation. This equipment generates, uses, and can radiate radio frequency energy and, if not installed and used in accordance with the instructions, may cause harmful interference to radio communications. However, there is no guarantee that interference will not occur in a particular installation. If this equipment does cause harmful interference to radio or television reception, which can be determined by turning the equipment off and on, the user is encouraged to try to correct the interference by one or more of the following measures:</p> <ul style="list-style-type: none"> - Reorient or relocate the receiving antenna. - Increase the separation between the equipment and receiver. - Connect the equipment into an outlet on a circuit different from that to which the receiver is connected. - Consult the dealer or an experienced radio / TV technician for help. <p>Means of conformity This transmitter must not be co-located or operated in conjunction with any other antenna or transmitter.</p> <p>This equipment complies with FCC radiation exposure limits set forth for an uncontrolled environment and meets the FCC radio frequency (RF) Exposure Guidelines. This equipment has very low levels of RF energy that is deemed to comply without maximum permissive exposure evaluation (MPE). But it is desirable that it should be installed and operated keeping the radiator at least 20cm or more away from person's body.</p>
California, U.S.A.	Proposition65	<div style="border: 1px solid black; padding: 5px;"> <p> WARNING: This product can expose you to chemicals including Lead, which is known to the State of California to cause birth defects or other reproductive harm. For more information go to www.P65Warnings.ca.gov.</p> </div>

Region/ Country	Directives/ Regulations	Labels/Declarations
California, and NY, U.S.A.	Recycling Batteries	<p style="text-align: center;"><u>DON'T THROW AWAY RECHARGEABLE BATTERIES, RECYCLE THEM.</u></p> <p style="text-align: center;"><u>Topcon Positioning Systems Inc., United States Return Process for Used Rechargeable Nickel Metal Hydride, Nickel Cadmium, Small Sealed Lead Acid, and Lithium Ion, Batteries</u></p> <p>In the United States Topcon Positioning Systems Inc., has established a process by which Topcon customers may return used rechargeable Nickel Metal Hydride(Ni-MH), Nickel Cadmium(Ni-Cd), Small Sealed Lead Acid(Pb), and Lithium Ion(Li-ion) batteries to Topcon for proper recycling and disposal. Only Topcon batteries will be accepted in this process.</p> <p>Proper shipping requires that batteries or battery packs must be intact and show no signs of leaking. The metal terminals on the individual batteries must be covered with tape to prevent short circuiting and heat buildup or batteries can be placed in individual plastic bag. Battery packs should not be disassembled prior to return.</p> <p>Topcon customers are responsible for complying with all federal, state, and local regulations pertaining to packing, labeling, and shipping of batteries. Packages must include a completed return address, be prepaid by the shipper, and travel by surface mode. <u>Under no circumstance should used/recyclable batteries be shipped by air.</u></p> <p>Failure to comply with the above requirements will result in the rejection of the package at the shipper's expense.</p> <p>Please remit packages to: Topcon Positioning Systems, Inc. C/O Battery Return Dept. 150 7400 National Dr. Livermore, CA 94551</p> <p style="text-align: center;"><u>DON'T THROW AWAY RECHARGEABLE BATTERIES, RECYCLE THEM.</u></p>
Canada	ICES-Class B	<p>This class B digital apparatus meets all requirements of Canadian interference-Causing Equipment Regulations. Cet appareil numérique de la class B respecte toutes les exigences du Règlement sur le matériel brouilleur du Canada.</p> <p>This Class B digital apparatus complies with Canadian ICES-003 Cet appareil numérique de la Class B est conforme a la norme NMB-003 du Canada.</p> <p>This equipment complies with IC radiation exposure limits set forth for an uncontrolled environment and meets the RSS-102 of the IC radio frequency (RF) Exposure Guidelines. This equipment has very low levels of RF energy that is deemed to comply without maximum permissive exposure evaluation (MPE). But it is desirable that it should be installed and operated keeping the radiator at least 20cm or more away from person's body.</p>

Region/ Country	Directives/ Regulations	Labels/Declarations
EU/UK	EMC-Class B RE	<p>EMC NOTICE In industrial locations or in proximity to industrial power installations, this instrument might be affected by electromagnetic noise. Under such conditions, please test the instrument performance before use.</p> <p>Hereby, TOPCON CORPORATION declares that the radio equipment type of this product is in compliance with Directive 2014/53/EU. The full text of the EU declaration of conformity is available at the following internet address: https://mytopconnow.topconpositioning.com</p> <p>Manufacturer Name: TOPCON CORPORATION Address: 75-1, Hasunuma-cho, Itabashi-ku, Tokyo, 174-8580 JAPAN</p> <p>Europe Representative and Importer Name: Topcon Europe Positioning B.V. Address: Essebaan 11, 2908 LJ Capelle a/d IJssel, The Netherlands</p> <p>UK Importer Name: Topcon Positioning (Great Britain) Ltd. Address: Unit 2 Sandy Hill Park, Sandy Way, Tamworth, Staffordshire B77 4DU U.K</p>
EU UK	WEEE Directive The Waste Electrical and Electronic Equipment Regulations	 <p>The use of the symbol indicates that this product may not be treated as household waste. By ensuring this product is disposed of correctly, you will help prevent potential negative consequences for the environment and human health, which could otherwise be caused by inappropriate waste handling of this product. For more detailed information about the take-back and recycling of this product, please contact your supplier where you purchased the product or consult.</p>
EU UK	EU Battery Directive The Waste Batteries and Accumulators Regulations 2009	 <p>Battery users must not dispose of batteries as unsorted general waste, but treat properly.</p> <p>If a chemical symbol is printed beneath the symbol shown above, this chemical symbol means that the battery or accumulator contains a heavy metal at a certain concentration. This will be indicated as follows: Hg: mercury(0.0005%), Cd: cadmium(0.002%), Pb: lead(0.004%)</p> <p>These ingredients may be seriously hazardous to human and the global environment.</p>

Region/ Country	Directives/ Regulations	Labels/Declarations																																																
China	Chinese Environmental Directive	<p style="text-align: center;"><产品中有毒有害物质的名称及含量></p> <table border="1" style="width: 100%; border-collapse: collapse;"> <thead> <tr> <th rowspan="2" style="width: 15%;">部件名称</th> <th colspan="6" style="text-align: center;">有 害 物 质</th> </tr> <tr> <th style="width: 10%;">铅 (Pb)</th> <th style="width: 10%;">汞 (Hg)</th> <th style="width: 10%;">镉 (Cd)</th> <th style="width: 10%;">六价铬 (Cr (VI))</th> <th style="width: 10%;">多溴联苯 (PBB)</th> <th style="width: 10%;">多溴二苯醚 (PBDE)</th> </tr> </thead> <tbody> <tr> <td>旋转激光部位</td> <td style="text-align: center;">×</td> <td style="text-align: center;">○</td> <td style="text-align: center;">○</td> <td style="text-align: center;">○</td> <td style="text-align: center;">○</td> <td style="text-align: center;">○</td> </tr> <tr> <td>主机部位</td> <td style="text-align: center;">×</td> <td style="text-align: center;">○</td> <td style="text-align: center;">○</td> <td style="text-align: center;">○</td> <td style="text-align: center;">○</td> <td style="text-align: center;">○</td> </tr> <tr> <td>电源部位</td> <td style="text-align: center;">×</td> <td style="text-align: center;">○</td> <td style="text-align: center;">○</td> <td style="text-align: center;">○</td> <td style="text-align: center;">○</td> <td style="text-align: center;">○</td> </tr> <tr> <td>附件</td> <td style="text-align: center;">×</td> <td style="text-align: center;">○</td> <td style="text-align: center;">○</td> <td style="text-align: center;">○</td> <td style="text-align: center;">○</td> <td style="text-align: center;">○</td> </tr> <tr> <td>盒子</td> <td style="text-align: center;">○</td> <td style="text-align: center;">○</td> <td style="text-align: center;">○</td> <td style="text-align: center;">○</td> <td style="text-align: center;">○</td> <td style="text-align: center;">○</td> </tr> </tbody> </table> <p>○：表示该有毒有害物质在该部件所有均质材料中的含量均在电子信息产品中有毒有害物质的限量要求标准规定的限量要求（GB/T 26572）以下 ×：表示该有毒有害物质至少在该部件的某一均质材料中的含量超出电子信息产品中有毒有害物质的限量要求标准规定的限量要求（GB/T 26572）</p> <p>This information is applicable for People's Republic of China only.</p> <div style="border: 1px solid black; padding: 5px; margin-top: 10px;">  <p>环保使用期限标识是根据《电器电子产品有害物质限制使用管理办法》以及《电器电子产品有害物质限制使用标识要求》（SJ/T11364）制定的，适用于中国境内销售的电子信息产品的标识。</p> <p>只要按照安全及使用说明内容在正常使用电子信息产品情况下，从生产日期算起，在此期限内产品中含有的有毒有害物质不致发生外泄或突变，不致对环境造成严重污染或对其人身、财产造成严重损害。产品正常使用后，要废弃在环保使用年限内或者刚到年限的产品，请根据国家标准采取适当的方法进行处置。另外，此期限不同于质量/功能的保证期限。</p> <p>The Mark and Information are applicable for People's Republic of China only.</p> </div>	部件名称	有 害 物 质						铅 (Pb)	汞 (Hg)	镉 (Cd)	六价铬 (Cr (VI))	多溴联苯 (PBB)	多溴二苯醚 (PBDE)	旋转激光部位	×	○	○	○	○	○	主机部位	×	○	○	○	○	○	电源部位	×	○	○	○	○	○	附件	×	○	○	○	○	○	盒子	○	○	○	○	○	○
部件名称	有 害 物 质																																																	
	铅 (Pb)	汞 (Hg)	镉 (Cd)	六价铬 (Cr (VI))	多溴联苯 (PBB)	多溴二苯醚 (PBDE)																																												
旋转激光部位	×	○	○	○	○	○																																												
主机部位	×	○	○	○	○	○																																												
电源部位	×	○	○	○	○	○																																												
附件	×	○	○	○	○	○																																												
盒子	○	○	○	○	○	○																																												

TOPCON CORPORATION (Manufacturer)

75-1 Hasunuma-cho, Itabashi-ku, Tokyo 174-8580, Japan <https://www.topcon.co.jp>

Please see the following website for contact addresses.

GLOBAL GATEWAY <https://global.topcon.com>
